

Medium-voltage sensors

for the use in the smart grid



www.mbs-ag.com



Medium-voltage sensors

Our medium-voltage sensors are designed for using in the secondary energy distribution. They are type and routine tested according to IEC 60044-7 (voltage sensors) and IEC 60044-8 (current sensors).

Applications

Through the consequent extension of renewable energies in the grid, it will become harder to cope with fluctuating voltage levels.

Due to the fact, that in most cases additional underground cables or landlines are very expensive and simply not possible to install the only way is, to make the grid smart.

Since the primary energy distribution is already completely equipped with conventional transformers, there are often used adjustable transformers in the secondary sub stations – so called Ring Main Units (RMU). The required voltage measurements can then be implemented in a space-saving and efficient manner by voltage sensors for installation in T-connectors. Also earth fault detection or protection devices can be supplied with an accurate voltage signal without any further calibration.

The current measurement is also realized by sensors acc. To IEC 60044-8, which are very easy to install.

Installation

Current- and voltage sensors will be mounted inside the cable compartment of a ring main unit. In this housing, you can find the T-connectors (see below).

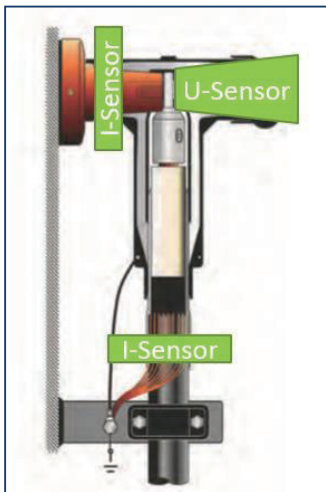

For first installation of new ring main units the current sensor on the upper left side is used, which is mounted over the bushing of the line.

This solution is more cost effective and higher accuracy classes are possible.

For retrofit installations, another current sensor is used. This sensor is divisible and could be easily mounted on the cable which connects the ring main units together.

The voltage sensor is designed for first and retrofit installation. To equip a cable with this sensor, it is only necessary to remove the basic insulating plug from the T-connector and screw the sensor in.

It is not necessary to make an adjustment of the sensors in the field, due to all sensors are factory calibrated delivering a signal according to the IEC standard.

Function principle

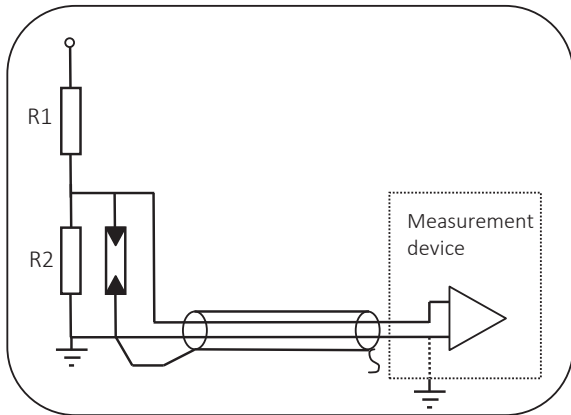

The voltage sensor based on the principle of an ohmic divider, which is adjusted in the factory to the guaranteed accuracy level. It is only necessary to know the ohmic part of the input impedance of the measurement device, due to the sensor is insensitive against changes in the capacitance.

The current sensor bases on the transformer principle. The coil is connected to high precision shunt. Due to the measurement devices on the market exist with and without the possibility of an earth connection, a special design of the sensor allows to adapt to different earth connection systems. For those an additional connection point is used, which is closed by a screw.

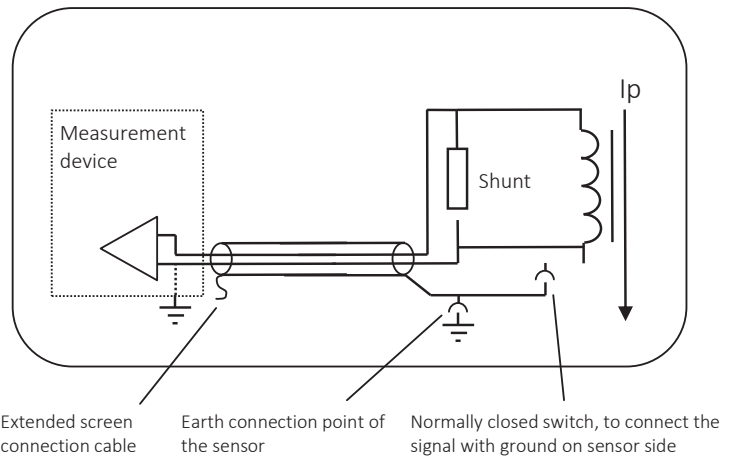

Constructive design with double casting

The patented double casting ensures a stable primary capacity over the entire lifetime. Expensive recalibrations are not required. The working temperature range of $-40...+80\text{ }^{\circ}\text{C}$ underlines the quality of the sensors.

Voltage sensor as basic insulating plug in T-connector

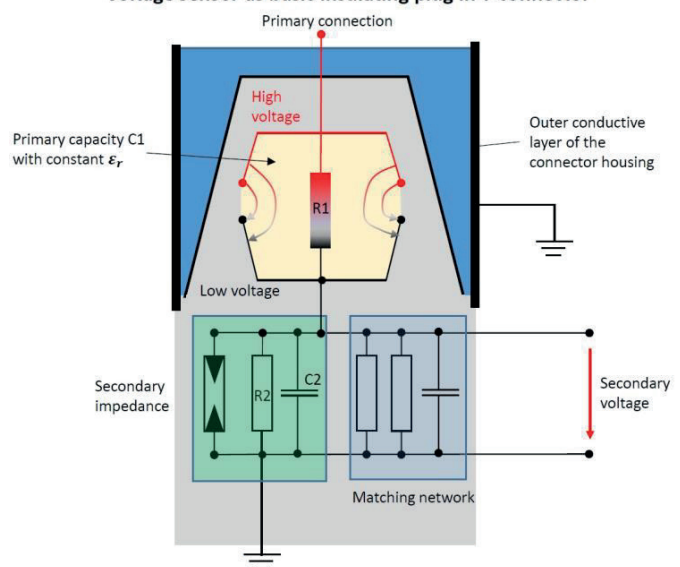

Voltage sensors



All voltage sensors are type and routine tested according to IEC60044-7 (future IEC61869-10, passive stand-alone)

VSP12-S / VSP24-S

12-24kV voltage sensor for type C cone according to EN50181 and EN50180



VAP12-S / VAP24-S

12-24kV voltage sensor for asymmetric T-connectors



Technical parameters – voltage sensors

VSP12-R / VSP24-R & VAP12-R / VAP24-R		
VSP12-S / VAP12-S	Isolation level	12 / 28 / 75kV
	Nominal voltage	10/ $\sqrt{3}$ kV or 11/ $\sqrt{3}$ kV
VSP24-S / VAP24-S	Isolation level	24 / 50 / 125kV
	Nominal voltage	20/ $\sqrt{3}$ kV or 22/ $\sqrt{3}$ kV
Nominal frequency	50Hz	
Secondary output	3.25/ $\sqrt{3}$ V or customer defined	
Rated overvoltage factor	1.9 U_N / 8h	
Accuracy classes	0.2 / 0.5 / 1 / 3 & 3P / 6P	
Standard	IEC60044-7 / IEC61869-10 (future)	
Input impedances of measurement devices	200k Ω ¹ ; Capacitance max. 5nF	
Connection	2 pole, open wires inclusive screen, cable length in 2m, 10m and 20m	
Temperature range	Working and storage: -40 to +80°C	
T-connector for VSP12-R / VSP24-R	Südkabel, Nexans, Prysmian, 3M	
T-connector for VAP12-R / VAP24-R	Südkabel, Nexans, nkt, Raychem, Cellpack, 3M ³	

¹ Accuracy of input impedance of measurement device influences the accuracy of the whole measurement system

Rule of thumb: +/-1% means an additional error of approx. 0.1% in the amplitude

² Cable length could be cut by customer, if it is necessary

³ A multi-compatible sensor for the short cone is used

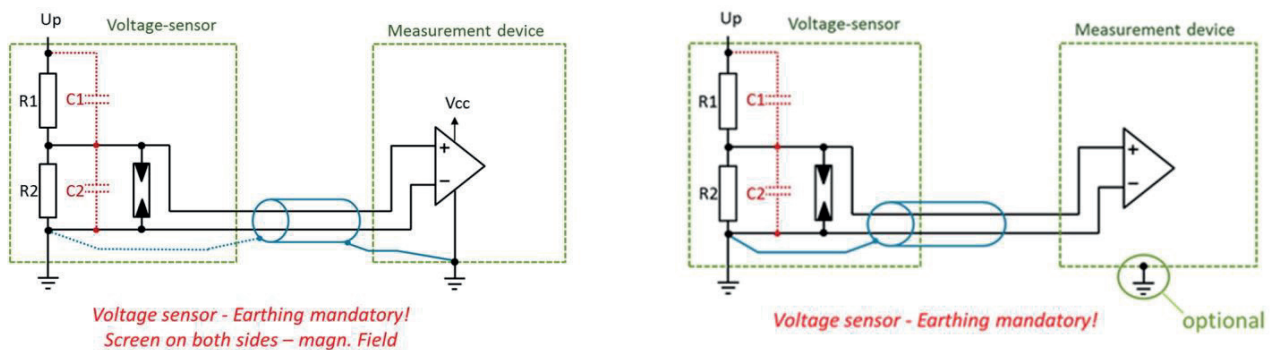

Due to electromagnetic compatibility, it is mandatory to adopt the connection configuration to the measurement device.

The voltage has to be earthed in any case, which makes it necessary to give the customer the possibility to connect the earth of the measurement to the earth of the voltage sensor.

In common mode both components Sensor + device are earthed to avoid magnetic interferences.

Current sensors



All current sensors are type and routine tested according to IEC 60044-8 (future IEC61869-11, passive stand-alone)

CSR 80



The non-divisible current sensor N030R is mounted over the bushing of the t-connector

Holders on inner diameter are exchangeable to fit on any T-connector outer diameter

CSO 55

The divisible current sensor N030T, is mounted around the cable

The flexible clamps system allows an easy and reliable installation on any cable up to 55mm diameter



Earth fault sensors

The special design of the earth fault sensor allows a highly flexible use case of the sensor, which fits to nearly all substations with different pole distances.

CSOD 55



The earth fault sensor consists of 3 divisible sensors. The signal is delivered from the main sensor in the middle. Complimentary sensors on right/left deliver the signal for calculation of residual current.

Technical parameters – current sensors

CSR 80 & CSO 55	
Isolation level	0.72 / 3 / -kV
Nominal primary current	300A, extension 200% cont. or customer defined
Secondary output	225mV acc. IEC or customer defined
Nominal frequency	50Hz
Accuracy classes	CSR 80 0.2S / 0.2 / 0.5S / 0.5 / 1 / 3 & max. 5P20
Accuracy classes	CSO 55 0.5S / 0.5 / 1 / 3 & max. 5P20
Therm. rated short-time current	25kA / 3sec.
Standard	IEC60044-8 / IEC61869-11 (future)
Input impedances of measurement devices	> 20kΩ ¹ ; capacitance not relevant
Connection	2 pole, open wires inclusive screen
Temperature range	Working and storage: -40 to +80°C

¹ The input impedance of the measurement device influences the accuracy of the whole system. The higher the impedance the better it is. With 20kΩ an additional effort of 0.02% in amplitude will be generated.

Technical parameters – earth fault sensors

CSOD 55	
Isolation level	0.72 / 3 / -kV
Nominal primary current	60A or customer defined
Secondary output	225mV acc. IEC or customer defined
Nominal frequency	50Hz
Accuracy classes	0.5 / 1 / 3 & max. 5P100 (6000A)
Therm. rated short-time current	25kA / 3sec.
Standard	IEC60044-8 / IEC61869-11 (future)
Input impedances of measurement devices	$> 20k\Omega^1$; capacitance not relevant
Connection	2 pole, open wires inclusive screen
Temperature range	Working and storage: -40 to $+80^\circ\text{C}$

¹ The input impedance of the measurement device influences the accuracy of the whole system. The higher the impedance the better it is. With $20k\Omega$ an additional effort of 0.02% in amplitude will be generated.

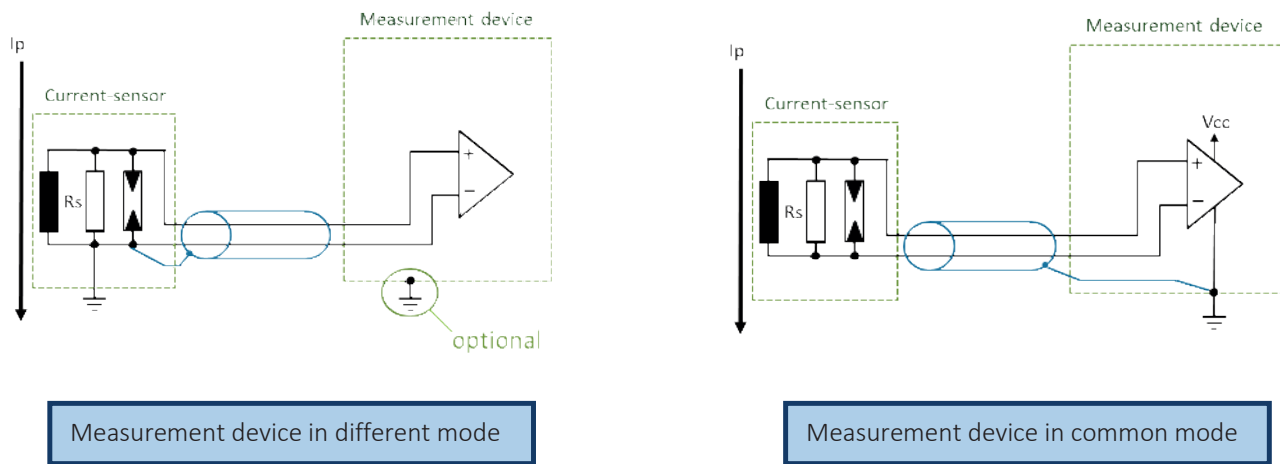

Due to electromagnetic compatibility, it is mandatory to adapt the connection configuration to the measurement device. The current sensors could be applied on measurement devices, doesn't matter which mode is used common or differential mode.

A additional switch in the current sensors Screw is used to open the connection between shunt and earth to adapt it to measurement device in common mode.

Available options and accuracy classes

Our medium-voltage sensors can be supplied in various designs and accuracy classes on customer request, to offer the right sensor for every application.

Level „C“ Class 1	Earth fault and earth fault direction detection
Level „L“ Class 0,5	Voltage limit control and other compensation controls
Level „M“ Class 0,2	High accurate measuring
Level „H1“ Class 0,2 + Measuring up to 2.5kHz	High accurate measuring and power quality monitoring up to 2.5 kHz
Level „H2“ Class 0.2 + Measuring up to 9kHz	High accurate measuring and power quality monitoring up to 9 kHz
Level „H3“ Class 0.2 + Measuring up to 150kHz	High accurate measuring and power quality monitoring up to 150 kHz

Features and benefits

- **Resistance against** temperature and humidity fluctuations over the entire lifetime
- Extreme high temperature range from **-40°C to +80°C**
- Accuracy classes of sensors designed for all customer needs
- Short form factor of voltage sensors VAP12-S / VAP24-S -> 24kV version is as long as the standard basic insulating plug of the T-connector -> **no installation problems**
- **Hexagonal nut is made of solid metal**, therefore no abrasion or damage at higher tightening torques
- Voltage sensors may **remain** in the T-connector during **VLF cable testing**
- Length of the **connection cable** is **free** and must not be adjusted to the sensor
- The **input impedance** of the connected measuring device **must not take into account**
- The sensors VAP12-S / VAP24-S are **multi-compatible** with all **T-cable connector manufacturers**

Device compatibility

- Siemens – FCM, SC80 and 7SJ80/7SJ81
- Kries – IKI50
- Horstmann – Compass B
- Elvac – RTU7K
- A. eberle – EOR-3D
- Sprecher Automation – E-DIR

ECO-sensors with correction factors



Our current and voltage sensors are optionally available in the ECO series, which operate with correction factors and have a maximum accuracy class of 0.5 / 1 / 3.

Technical parameters – ECO sensors

ECO-voltage sensors with correction factor	
Isolation level	12 / 28 / 75kV or 24 / 50 / 125kV
Nominal primary voltage	10/ $\sqrt{3}$ kV or 20/ $\sqrt{3}$ kV
Secondary output	3.25/ $\sqrt{3}$ V acc. IEC
Accuracy classes	0.5 / 1 / 3
Input impedances of measurement devices	Siemens SICAM FCM or others
Temperature range	Working and storage: -40 to +80°C
T-connector for VSP12-R / VSP24-R	Südkabel, Nexans, Prysmian, 3M
T-connector for VAP12-R / VAP24-R	Südkabel, Nexans, nkt, Raychem, Cellpack, 3M ¹
ECO-current sensors with correction factor	
Isolation level	0.72 / 3 / -kV
Nominal primary current	300A or 60A, extension 200% cont.
Secondary output	225mV acc IEC
Accuracy classes	0.5 / 1
Input impedances of measurement devices	> 20k Ω ² ; capacitance not relevant
Temperature range	Working and storage: -40 to +80°C

¹ A multi-compatible sensor is used

² The input impedance of the measurement device influences the accuracy of the whole system. The higher the impedance the better it is. With 20k Ω an additional effort of 0.02% in amplitude will be generated.



- Current transformers for industry
- Current transformers for tariffs
- Accessories for current transformers
- Medium-voltage transformers

- Bus bar insulators / -supports
- Shunts
- Voltage transformers
- All current sensors
- Measuring transducers
- Energy meters with or without MID approval
- Accessories for energy meters
- Panel board heaters, filter fans, roof fans and control units



www.mbs-ag.com

MBS AG
Eisbachstraße 51 74429 Sulzbach-Laufen Germany
Phone: +49 7976 9851-0 Telefax: +49 7976 9851-90
info@mbs-ag.com www.mbs-ag.com

