

Bus bar isolators/ -supports



www.mbs-ag.com





**We design
the future for you
TODAY !**



Bus bar isolators / -supports

Seite

Spacing isolator Type DB/P

4

Spacing isolator Type CO/P

8

Spacing isolator Type CS/P

9

Spacing isolator Type CT/P

10

Spacing isolator Type CPE

11

Passing isolator Type PI/P

12

Vertical bus bar support Type PSB

14

Bus bar support L

16

Bus bar support Z

17

Spacing isolator Type DB/P



Made of Polyglas-polyester material, reinforced with fiberglass, colour red, self extinguishing. The isolators of type DB are unbreakable and have excellent electrical and mechanical characteristics and can be used under extreme working conditions such as high room temperatures, also when in contact with corrosive substances, vibrations, etc.

The hexagon, arranged middle layer with two facing sides, facilitates the connection and locking in place the isolator.

Upon request, the isolators can be supplied as follows:

- The isolator can be equipped with a thread which is not standard
- The isolator can be supplied with one or two threaded bolts „GB“

Operating temperature: $-40^{\circ}\text{C} < T < +130^{\circ}\text{C}$

Fire resistance class: UL 94-V0

All products are also available with matching threaded bolts.

Please contact us.

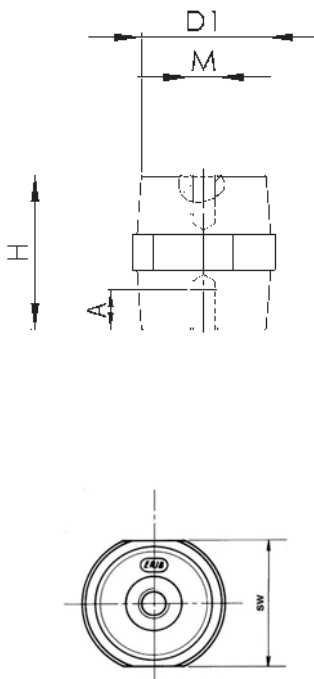

Art.-no.	Type	H [mm]	sw* [mm]	D1 [mm]	U_M [V]	M	A [mm]	Colour	Pac [pcs.]
90015	DB/P 12	12	11	10	220	M3	3	black	100
90018	DB/P 12	12	11	10	220	M4	3	red	100
90022	DB/P 16	16	14	13	380	M4	4	red	100
90025	DB/P 20	20	17	15	500	M4	6	red	100
90026	DB/P 20	20	17	15	500	M6	6	red	100
90028	DB/P 25	25	19	15	600	M6	7	black	250
90029	DB/P 25	25	19	15	600	M5	7	red	250
90030	DB/P 25	25	19	15	600	M6	7	red	250
90033	DB/P 30	30	30	26	600	M6	8	red	80
90034	DB/P 30	30	30	26	600	M8	7	red	80
90035	DB/P 34	35	32	28	1000	M6	9	red	64
90036	DB/P 34	35	32	28	1000	M8	10	red	64
90037	DB/P 34	35	32	28	1000	M10	10	red	64
90038	DB/P 35	35	41	35	1000	M6	9	red	36
90039	DB/P 35	35	41	35	1000	M8	9	red	36
90040	DB/P 35	35	41	35	1000	M10	10	red	36
90438	DB/P 40	40	40	30	1000	M8	11	red	100
90439	DB/P 40	40	40	30	1000	M10	12	red	100
90440	DB/P 40	40	40	30	1000	M12	10	red	100
90041	DB/P 45	45	41	35	1500	M6	12	red	27
90042	DB/P 45	45	41	35	1500	M8	12	red	27
90043	DB/P 45	45	41	35	1500	M10	12	red	27
90044	DB/P 45	45	41	35	1500	M12	12	red	27
90046	DB/P 50	51	36	29	2000	M8	12	red	36
90047	DB/P 50	51	36	29	2000	M10	12	red	36
90048	DB/P 50	51	36	29	2000	M12	13	red	36
90441	DB/P 60	60	55	40	2000	M8	20	red	25
90442	DB/P 60	60	55	40	2000	M10	21	red	25
90443	DB/P 60	60	55	40	2000	M12	20	red	25
90050	DB/P 65	63,5	41	35	3000	M8	17	red	22
90051	DB/P 65	63,5	41	35	3000	M10	19	red	22
90052	DB/P 65	63,5	41	35	3000	M12	19	red	22
90053	DB/P 75	76	50	36	5000	M8	19	red	12
90054	DB/P 75	76	50	36	5000	M10	19	red	12
90055	DB/P 75	76	50	36	5000	M12	19	red	12
90057	DB/P 750	75	65	52	5000	M12	18	red	8
90058	DB/P 750	75	65	52	5000	M16	23	red	8

*sw=wrench width

Type	Thread	Ripple current resistance [kV]	Discharge voltage [kV]	Max. tensile load [kN]	Max. bending load [kN]	Max. compression load [kN]	Max. tightening torque [Nm]
DB/P 16	M4	3	8	1	0,5	5	2,8
DB/P 20	M4	4	15	1,5	0,6	6	2,8
DB/P 20	M6	4	15	1,5	0,6	6	8,9
DB/P 25	M5	7	20	3	1,8	21	5,1
DB/P 25	M6	7	20	3	1,8	21	8,9
DB/P 30	M6	8	23	5	2,5	44	8,9
DB/P 30	M8	8	23	5	2,5	44	21,5
DB/P 34	M6	10	30	8	4,5	65	8,9
DB/P 34	M8	10	30	8	4,5	65	21,5
DB/P 34	M10	10	30	8	4,5	65	43,0
DB/P 35	M6	10	30	11	8	80	8,9
DB/P 35	M8	10	30	11	8	80	21,5
DB/P 45	M6	12	40	12	8	80	8,9
DB/P 45	M8	12	40	12	8	80	21,5
DB/P 45	M10	12	40	12	8	80	43,0
DB/P 45	M12	12	40	12	8	80	85,0
DB/P 50	M8	12	40	8,5	4,5	68	21,5
DB/P 50	M10	12	40	8,5	4,5	68	43,0
DB/P 50	M12	12	40	8,5	4,5	68	85,0
DB/P 65	M8	15	40	15	7	83	21,5
DB/P 65	M10	15	40	15	7	83	43,0
DB/P 65	M12	15	40	15	7	83	85,0
DB/P 75	M8	25	50	23	9	100	21,5
DB/P 75	M10	25	50	23	9	100	43,0
DB/P 75	M12	25	50	23	9	100	85,0
DB/P 750	M12	25	50	28	15	150	85,0
DB/P 750	M16	25	50	28	15	150	180,4

The spacing isolator type DB/P has been tested for dynamic short-circuit withstand strength according to the regulations covering IEC 61439-1+2: 2009-01.

Short-circuiting resistance of the isolators Type DB/P

SHORT-CIRCUITING RESISTANCE / ISOLATOR DISTANCE - Tab. 1

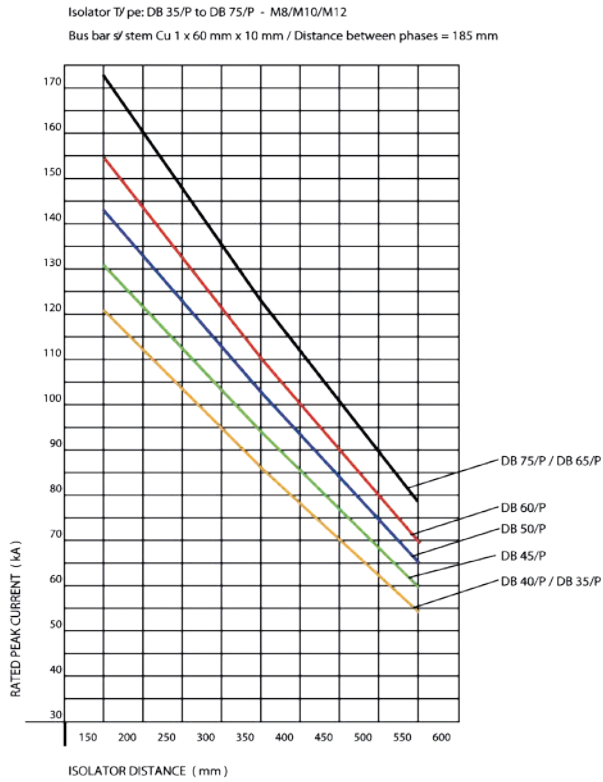

SHORT-CIRCUITING RESISTANCE / ISOLATOR DISTANCE - Tab. 2

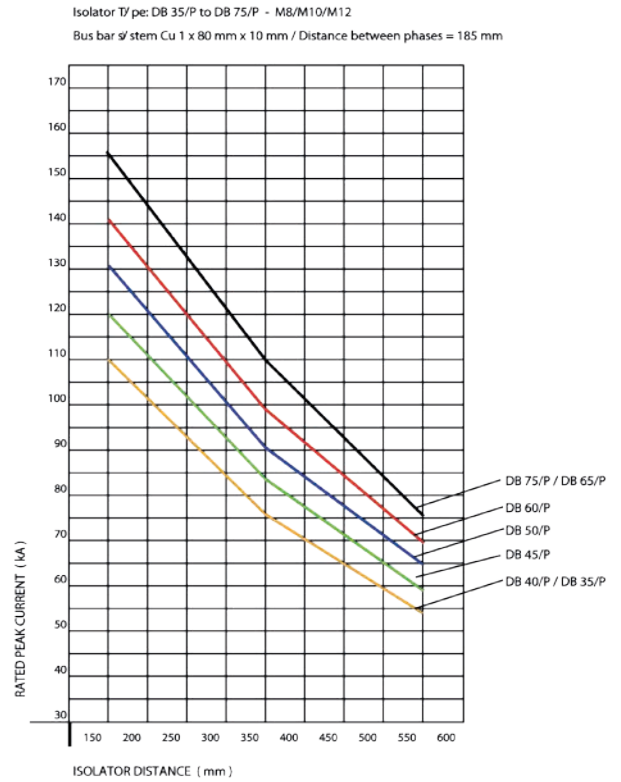

SHORT-CIRCUITING RESISTANCE / ISOLATOR DISTANCE - Tab. 3

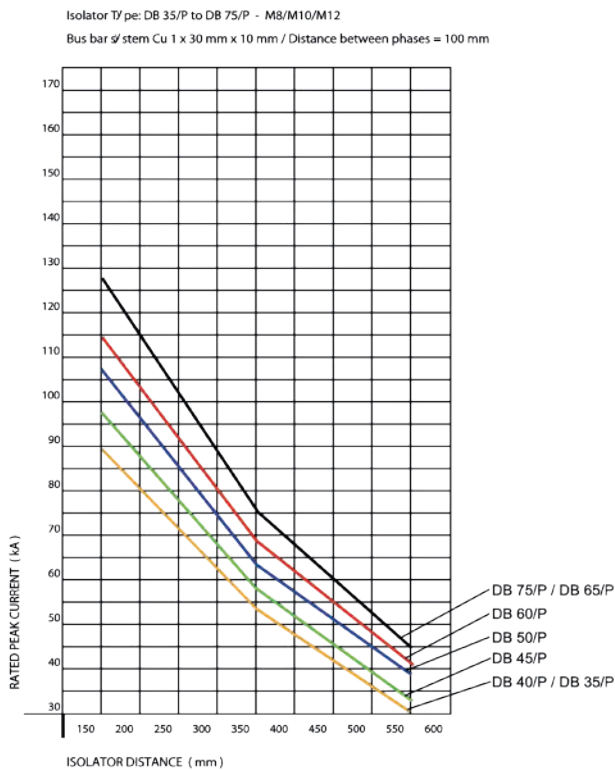

SHORT-CIRCUITING RESISTANCE / ISOLATOR DISTANCE - Tab. 4

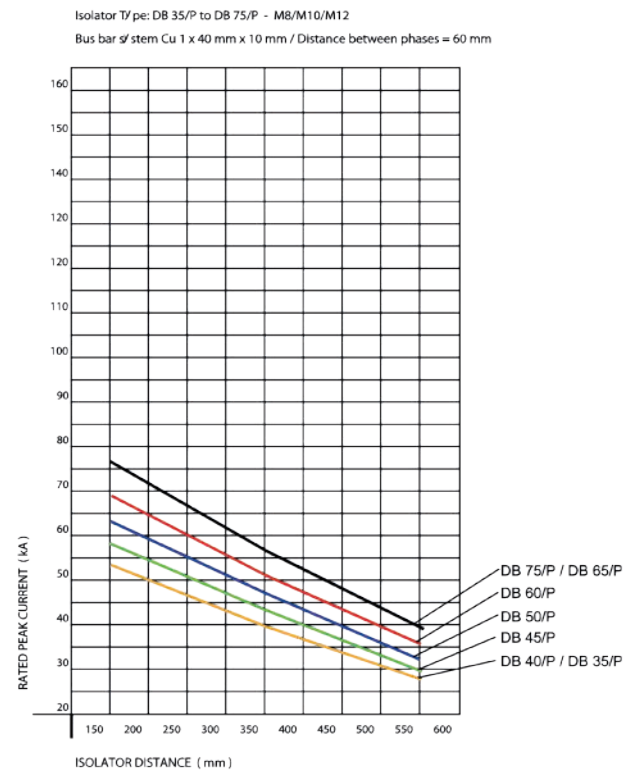



Independent, accredited testing station - Member laboratory of STL and LOVAG

TEST REPORT

NO. 1469.2101265.0692

MBS AG
Eisbachstraße 51
74429 Sulzbach-Laufen
GERMANY

CLIENT

Busbar systems: ERIM SRL, Novate Milanese
Distance insulators: MBS AG

MANUFACTURER

Busbar systems for low-voltage switchgear assemblies
with distance insulators

TEST OBJECT

DB/P 50 with M10 & M12 threads

TYPE

Test sample

SERIAL NO.

Rated operational voltage	U_n	400 V	RATED CHARACTERISTICS GIVEN BY THE CLIENT
Rated insulation voltage	U_i	1000 V	
Rated peak withstand current:			
30 mm x 10 mm up to	I_{pk}	63 kA	
40 mm x 10 mm up to	I_{pk}	106 kA	
60 mm x 10 mm up to	I_{pk}	132 kA	
80 mm x 10 mm up to	I_{pk}	144 kA	
Rated frequency	f	50 Hz	

IEC 61439-2: 2009-01, EN 61439-2: 2009-11

NORMATIVE DOCUMENT

Verification of dynamic short-circuit withstand strength

RANGE OF TESTS PERFORMED

12 to 14 October 2010

DATE OF TEST

See Sub-clause 4.6

TEST RESULT

RONALD BORCHERT
Senior engineer
Berlin, 25 November 2010

MICHAEL HEISE
Test engineer in charge



Independent test laboratory, accredited by Deutsche Akkreditierungsstelle Techn. (DAkks) e.V. in the fields of live apparatus and switching, power cables and power cable accessories, live apparatus and switchgear, installation equipment and switching and control equipment.



DAT - P - 019/92

ZERTIFIKAT CERTIFICATE CERTIFICADO CERTIFICAT CERTIFICADO CERTIFICAT CERTIFICATE CERTIFICATE CERTIFICATE



ZERTIFIKAT

Die Zertifizierungsstelle
der TÜV SÜD Management Service GmbH
bescheinigt, dass das Unternehmen



MBS AG
Eisbachstr. 51 • 74429 Sulzbach-Laufen
Deutschland

einschließlich der
Standorte und Geltungsbereiche
gemäß Anlage

ein Qualitätsmanagementsystem
eingeführt hat und anwendet.
Durch ein Audit, Auftrags-Nr. 70003062,
wurde der Nachweis erbracht, dass die Forderungen der

ISO 9001:2015

erfüllt sind.

Dieses Zertifikat ist gültig vom 05.04.2019 bis 04.04.2022.
Zertifikat-Registrier-Nr.: 12 100 20346 TMS.

Product Compliance Management
München, 08.04.2019



Seite 1 von 2

TÜV SÜD Management Service GmbH • Zertifizierungsstelle • Fidlerstrasse 57 • 80339 München • Germany
www.tuev-sued.de/certificate-validity-check



Unabhängiges, akkreditiertes Prüflaboratorium - Mitgliedsprüflab bei STL und LOVAG

PRÜFBERICHT

NR. 1469.2111429.0957

MBS AG
Eisbachstraße 51
74429 Sulzbach-Laufen

AUFTRAGGEBER

MBS AG

HERSTELLER

Sammelschiensysteme für Niederspannungs-
Schaltgerätekombinationen mit vertikalen Schienenhaltern Typ PSB, L & Z

PRÜFOBJEKT

PSB/1, PSB/2, PSB/10, PSB/120, Distanzstück PSB,
Schienenhalter L 100, Z 185-2

TIYP

90175, 90176, 90177, 90180, 28246,
90391, 90385

SERIEN-NR.

Bemessungsbetriebsspannung	U_n	400 V	BEMESSUNGS-DATEN NACH ANGABEN DES AUFTRAGGEBERS
Bemessungsisolationsspannung	U_i	1000 V	
Bemessungsstoßstromfestigkeit	I_{sk}	bis zu 264 kA	
Bemessungskurzzeitstromfestigkeit	I_{sw}	bis zu 120 kA, 1s	
Bemessungsfrequenz	f	50 Hz	

IEC 61439-2: 2011-08, EN 61439-2: 2012-06

PRÜFVORSCHRIFT

Nachweis der Kurzschlussfestigkeit

UMFANG DER PRÜFUNG

16. und 17. August 2012

DATUM DER PRÜFUNG

Siehe Punkt 4.6

PRÜFERGEBNIS

RONALD BORCHERT
Oberingenieur
Berlin, den 30. November 2012

MICHAEL HEISE
Verantwortlicher Prüflingenieur



Unabhängiges Prüflaboratorium, akkreditiert von der DAkks, Deutsche Akkreditierungsstelle GmbH, für die Bereiche Hochspannungstechnik, Anlagen und deren Komponenten, Kabel und Leitungen sowie industrielle Niederspannungstechnik.
IPH Institut für elektrische Hochleistungstechnik GmbH (IPH Berlin) ist ein Tochterunternehmen von ICS SpA, Italien.



Spacing isolator Type CO/P

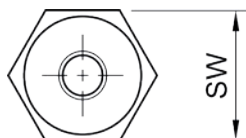
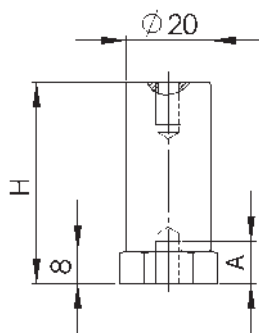

Made of Polyglas-polyester material, reinforced with fiberglass, colour red, self extinguishing.

Upon request the isolators type CO/P, can be supplied with 1 or 2 threaded bolts "GB", fitted and secured with Loctite.

Operating temperature: -40 °C up to +130 °C

Fire resistance class: UL94-V0

Art.-no.	Type	H [mm]	sw* [mm]	D1 [mm]	U _M [V]	M	A [mm]	Pac [pcs.]
90061	CO/P 16	16	21	20	220	M4	4	250
90062	CO/P 16	16	21	20	220	M5	4	250
90063	CO/P 16	16	21	20	220	M6	4	250
90064	CO/P 16	16	21	20	220	M8	4	250
90065	CO/P 20	20	21	20	400	M5	5	200
90066	CO/P 20	20	21	20	400	M6	5	200
90067	CO/P 20	20	21	20	400	M8	5	200
90068	CO/P 25	25	21	20	500	M5	6	150
90069	CO/P 25	25	21	20	500	M6	6	150
90070	CO/P 25	25	21	20	500	M8	6	150
90071	CO/P 30	30	21	20	600	M5	7	140
90072	CO/P 30	30	21	20	600	M6	7	140
90073	CO/P 30	30	21	20	600	M8	7	140
90075	CO/P 35	35	21	20	600	M6	7	120
90077	CO/P 40	40	21	20	600	M6	9	110
90078	CO/P 40	45	21	20	600	M8	10	110
90079	CO/P 45	45	21	20	750	M6	9	100
90080	CO/P 45	45	21	20	750	M8	10	100
90081	CO/P 50	50	21	20	750	M6	10	80
90082	CO/P 50	50	21	20	750	M8	10	80
90083	CO/P 60	60	21	20	750	M6	9	70
90084	CO/P 60	60	21	20	750	M8	9	70

*sw=wrench width

Type	Ripple current resistance [kV]	Discharge voltage [kV]	Max. tensile load [kN]	Max. bending load [kN]	Max. compression load [kN]	Max. tightening torque [Nm]
CO/P 16						2 - 10 Nm
CO/P 20						6 - 10 Nm
CO/P 25						6 - 14 Nm
CO/P 30	5	15	4	2	21	8 - 16 Nm
CO/P 35						6 - 12 Nm
CO/P 40	8	20	4	1,5	21	12 - 16 Nm
CO/P 45						12 - 16 Nm
CO/P 50	10	25	4	1	21	12 - 16 Nm
CO/P 60	10	30	4	1	21	12 - 16 Nm

Spacing isolator Type CS/P



Made of Polyglas-polyester material, reinforced with fiberglass, colour red, self extinguishing.

Operating temperature: $-40^{\circ}\text{C} < T < +130^{\circ}\text{C}$

Fire resistance class: UL 94-V0

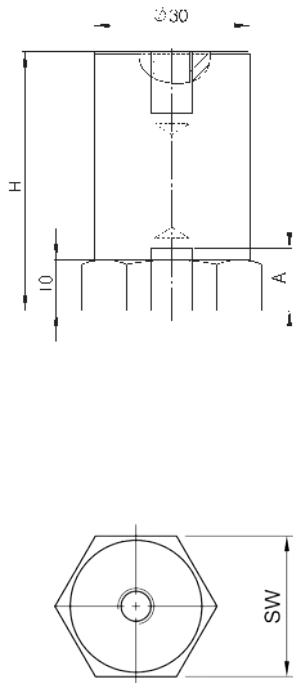

Art.-no.	Type	H [mm]	sw* [mm]	D1 [mm]	U_M [V]	M [mm]	A [mm]	Pac [pcs.]
90087	CS/P 30	30	30	30	750	M6	9	80
90088	CS/P 30	30	30	30	750	M8	9	80
90089	CS/P 30	30	30	30	750	M10	9	80
90090	CS/P 35	35	30	30	1000	M6	9	64
90091	CS/P 35	35	30	30	1000	M8	9	64
90092	CS/P 35	35	30	30	1000	M10	9	64
90093	CS/P 40	40	30	30	1000	M6	12	60
90094	CS/P 40	40	30	30	1000	M8	12	60
90095	CS/P 40	40	30	30	1000	M10	12	60
90096	CS/P 45	45	30	30	1000	M6	12	48
90097	CS/P 45	45	30	30	1000	M8	12	48
90098	CS/P 45	45	30	30	1000	M10	13	48
90099	CS/P 50	50	30	30	1500	M6	12	48
90100	CS/P 50	50	30	30	1500	M8	13	48
90101	CS/P 50	50	30	30	1500	M10	12	48
90102	CS/P 55	55	30	30	1500	M6	12	40
90103	CS/P 55	55	30	30	1500	M8	11	40
90105	CS/P 60	60	30	30	1500	M6	12	40
90106	CS/P 60	60	30	30	1500	M8	16	40
90107	CS/P 60	60	30	30	1500	M10	20	40
90109	CS/P 65	65	30	30	1500	M8	18	32
90111	CS/P 70	70	30	30	1500	M6	14	32
90112	CS/P 70	70	30	30	1500	M8	18	32
90113	CS/P 70	70	30	30	1500	M10	18	32

*sw=wrench width

Type	Ripple current resistance [kV]	Discharge voltage [kV]	Max. tensile load [kN]	Max. bending load [kN]	Max. compression load [kN]	Max. tightening torque [Nm]
CS/P 30	8	20	9	4,5	40	10 - 24 Nm
CS/P 40	8	25	9	3	40	10 - 24 Nm
CS/P 50	10	35	9	2	40	10 - 24 Nm
CS/P 60	15	35	9	1,5	40	10 - 24 Nm

Spacing isolator Type CT/P

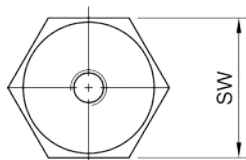
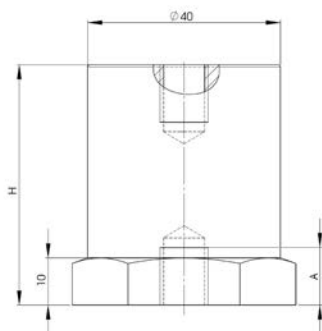

Made of Polyglas-polyester material, reinforced with fiberglass, colour red, self extinguishing.

Operating temperature: $-40^{\circ}\text{C} < T < +130^{\circ}\text{C}$

Fire resistance class: UL 94-V0

Art.-no.	Type	H [mm]	sw* [mm]	D1 [mm]	U_M [V]	M	A [mm]	Pac [pcs.]
90118	CT/P 30	30	41	40	750	M8	8	45
90119	CT/P 30	30	41	40	750	M10	9	45
90120	CT/P 35	35	41	40	750	M8	9	36
90121	CT/P 35	35	41	40	750	M10	9	36
90122	CT/P 40	40	41	40	1000	M8	12	27
90123	CT/P 40	40	41	40	1000	M10	12	27
90123M12	CT/P 40	40	41	40	1000	M12	12	27
90124	CT/P 45	45	41	40	1000	M8	13	27
90125	CT/P 45	45	41	40	1000	M10	12	27
90126	CT/P 50	50	41	40	1500	M8	12	27
90127	CT/P 50	50	41	40	1500	M10	13	27
90127M12	CT/P 50	50	41	40	1500	M12	11	27
90129	CT/P 55	55	41	40	1500	M10	12	18
90130	CT/P 60	60	41	40	1500	M8	18	18
90131	CT/P 60	60	41	40	1500	M10	18	18
90131M12	CT/P 60	60	41	40	1500	M12	18	18
90133	CT/P 65	65	41	40	1500	M10	18	18
90134	CT/P 70	70	41	40	1500	M8	18	18
90135	CT/P 70	70	41	40	1500	M10	18	18

*sw=wrench width

Type	Thread	Ripple current resistance [kV]	Discharge voltage [kV]	Max. tensile load [kN]	Max. bending load [kN]	Max. compression load [kN]	Max. tightening torque [Nm]
CT/P 30	M8	8	20	10	7,5	80	21,5
CT/P 30	M10	8	20	10	7,5	80	43,0
CT/P 40	M8	10	25	10	7	80	21,5
CT/P 40	M10	10	25	10	7	80	43,0
CT/P 40	M12	10	25	10	7	80	73,8
CT/P 50	M8	10	35	10	5	80	21,5
CT/P 50	M10	10	35	10	5	80	43,0
CT/P 50	M12	10	35	10	5	80	73,8
CT/P 60	M8	10	35	10	3,7	80	21,5
CT/P 60	M10	10	35	10	3,7	80	43,0
CT/P 60	M12	10	35	10	3,7	80	73,8

Spacing isolator Type CPE



Made of Polyglas-polyester material, reinforced with fiberglass, colour red, self extinguishing.

Operating temperature: $-40^{\circ}\text{C} < T < +130^{\circ}\text{C}$

Fire resistance class: UL 94-V0

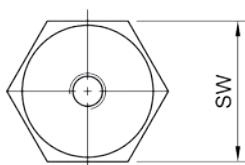
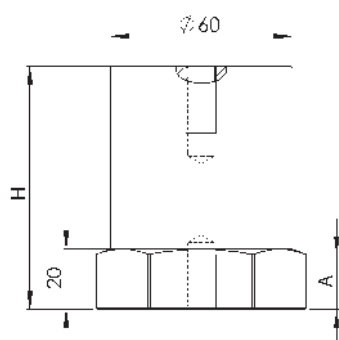

Art.-no.	Type	H [mm]	sw* [mm]	D1 [mm]	U_M [V]	M	A [mm]	Pac [pcs.]
90140	CPE 40	40	60	60	1500	M10	11	12
90141	CPE 40	40	60	60	1500	M12	11	12
90142	CPE 40	40	60	60	1500	M16	12	12
90143	CPE 60	60	60	60	3000	M10	18	10
90144	CPE 60	60	60	60	3000	M12	18	10
90145	CPE 60	60	60	60	3000	M16	19	10
90146	CPE 80	80	60	60	5000	M10	19	8
90147	CPE 80	80	60	60	5000	M12	19	8
90148	CPE 80	80	60	60	5000	M16	23	8
90149	CPE 100	100	60	60	8000	M10	19	5
90150	CPE 100	100	60	60	8000	M12	19	5
90151	CPE 100	100	60	60	8000	M16	23	5

*sw=wrench width

Type	Ripple current resistance [kV]	Discharge voltage [kV]	Max. tensile load [kN]	Max. bending load [kN]	Max. compression load [kN]	Max. tightening torque [Nm]
CPE 40	10	25	11	7	100	24 - 50 Nm
CPE 60	20	50	15	5	100	24 - 50 Nm
CPE 80	25	50	23	9	120	24 - 55 Nm
CPE 100	30	50	30	15	150	24 - 55 Nm

Passing isolator Type PI/P

Polyester material, red

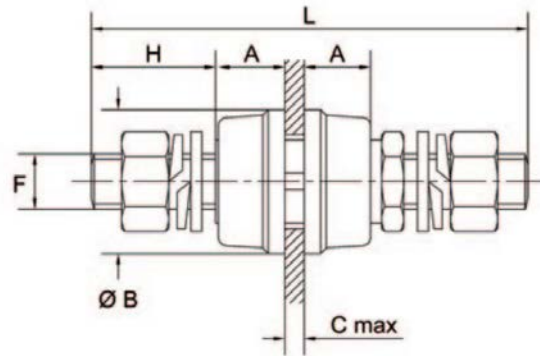

Art-no.	Type	Tightening torque	L (mm)	A (mm)	Ø B (mm)	C max (mm)	H (mm)	Ø 1 (mm)	Ø 2 (mm)	In rated range	Operating voltage
90166	PI/P 4	3 Nm	50	10	15	3	12,5	2,5	8,5	25A	600V
90167	PI/P 6	5 Nm	65	12	22	5	17	3,5	12,5	50A	1.000V
90168	PI/P 8	10 Nm	80	13,5	25	5	21	3,5	15,5	80A	1.000V
90169	PI/P 10	16 Nm	95	15	30	5	28	4,5	17,5	120A	1.000V
90170	PI/P 12	18 Nm	105	17	35	5	29	5	20,5	200A	1.000V
90171	PI/P 16	22 Nm	135	22	43	7	38	5,5	25,5	300A	2.000V
90172	PI/P 20	26 Nm	155	25	54	8	44	6	30,5	450A	2.000V

Vertical bus bar support Type PSB

Easy to assemble vertical bus bar support in polyester material with reinforced fibre glass, red, suitable for bus bars with dimensions between 40 x 60 mm and 120 x 10 mm. Due to its construction characteristics this bus bar support is suitable for special isolating and mechanical resistance requirements. For the mounting of a bus bar support the following parts are required:

1 or 2 lateral supports, two mounting screws and the necessary block number to clamp into place the required bus bars.

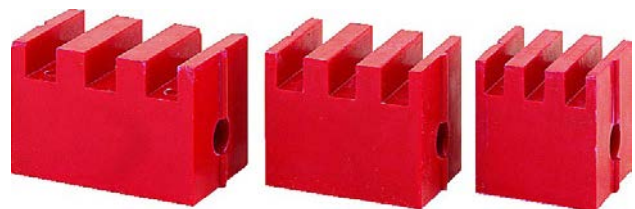

PSB/1 – Horizontal / lateral support

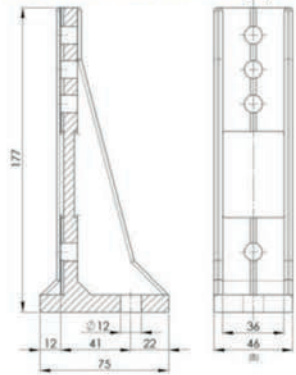

PSB/2 - Horizontal / lateral support

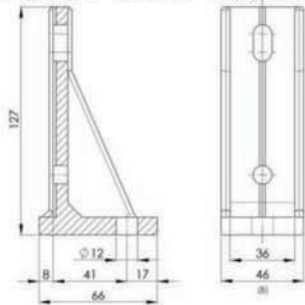

PSB/120 - Horizontal / lateral support

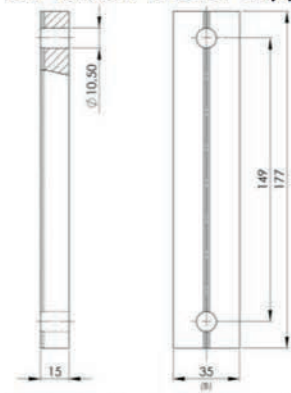

PSB/6 - Block for 6 mm bus bar

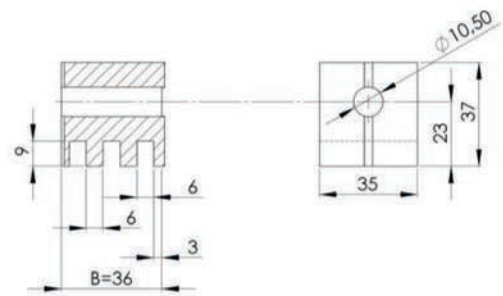

PSB/8 - Block for 8 mm bus bar

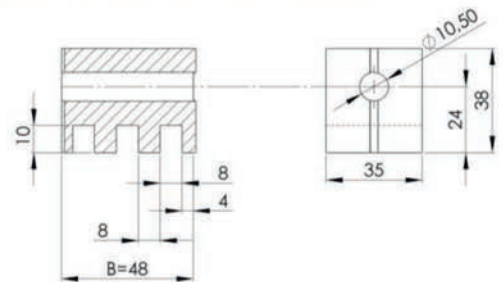

PSB/10 - Block for 10 mm bus bar

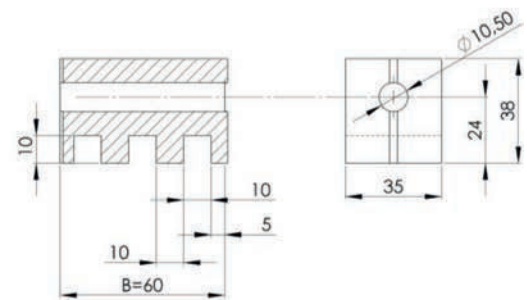

Lateral support	Blocks	Bus bars			Art.-no.
		60 x 6	80 x 6	100 x 6	
PSB/1	PSB 6	60 x 6	80 x 6	100 x 6	90175*
	PSB 8	60 x 8	80 x 8	100 x 8	
	PSB 10	60 x 10	80 x 10	100 x 10	
PSB/2	PSB 6	40 x 6	50 x 6		90176*
	PSB 8	40 x 8	50 x 8		
	PSB 10	40 x 10	50 x 10		
PSB/120	PSB 6	120 x 6			90177*
	PSB 8	120 x 8			
	PSB 10	120 x 10			

Elastic deviation of the teeth with signs of rupture			Pac (pcs.)	Art.-no.
PSB/6	kg	950	36	90178*
PSB/8	kg	1130	30	90179*
PSB/10	kg	1375	24	90180*

*=storage parts

Operating voltage 1000 V
 Operating temperature $-40^{\circ}\text{C} \leq q \leq +130^{\circ}\text{C}$
 Fire resistance class: UL94-V0

Vertical bus bar support Type PSB

Illustration 1

Example of an unipolar bus bar support with 3 parallel bus bar support holders

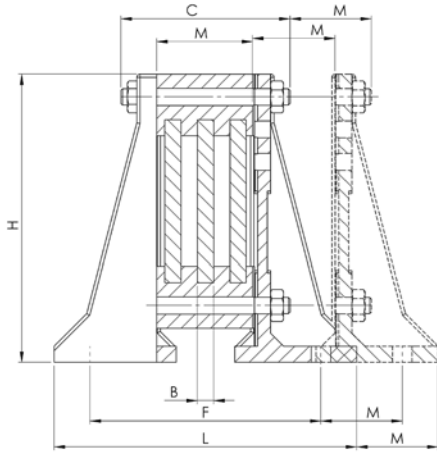

A=Number of blocks
 B=Bus bar thickness
 C=Length of mounting screw
 L=External space requirement
 H=Height
 M=Module

Illustrations 1 - 2 - 3 - 4 - 5 - 6
 show some of the possible variations.
 Illustrations up to max. 10x100 mm

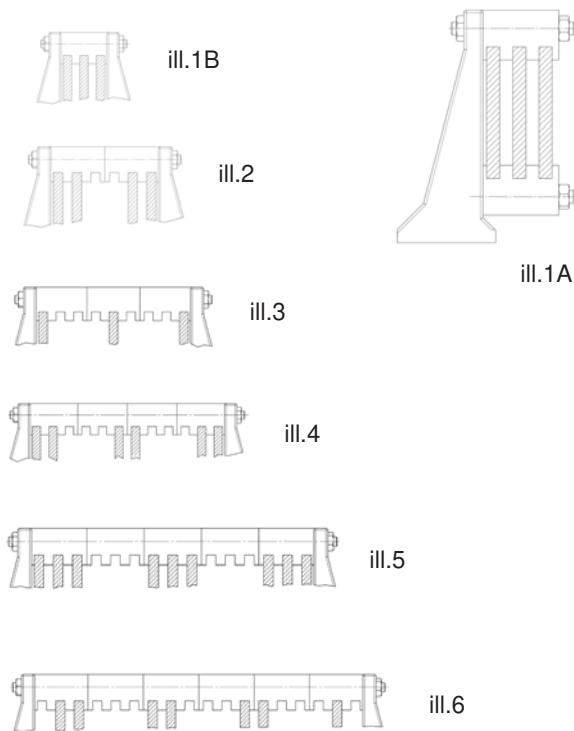

H. with lateral support PSB/1 = 177 mm
 PSB/2 = 127 mm
 M. with block PSB/6 = 36 mm
 PSB/8 = 48 mm
 PSB/10 = 60 mm

Art.-no.	Pac (pcs.)	Art.-group	H (mm)	B (mm)	U _M (V)	For thread
90175	96	PSB/1	177	46	1000	M10
90176	144	PSB/2	127	46	1000	M10
90177	244	PSB/120	177	35	1000	M10
90178	36	PSB/6	37	36	1000	M10
90179	30	PSB/8	38	48	1000	M10
90180	24	PSB/10	38	60	1000	M10

Art.-no.	Art-Group	ill.	H (mm)	L (mm)	U _M [V]	For thread	B [mm]
90187	PSB	1A	177		1000	M10	6
90188	PSB	1A	177		1000	M10	8
90189	PSB	1A	177		1000	M10	10
90190	PSB	1B	177	162	1000	M10	6
90191	PSB	1B	177	174	1000	M10	8
90192	PSB	1B	177	186	1000	M10	10
90193	PSB	2	177	198	1000	M10	6
90194	PSB	2	177	222	1000	M10	8
90195	PSB	2	177	246	1000	M10	10
90196	PSB	3	177	234	1000	M10	6
90197	PSB	3	177	270	1000	M10	8
90198	PSB	3	177	306	1000	M10	10
90199	PSB	4	177	270	1000	M10	6
90200	PSB	4	177	318	1000	M10	8
90201	PSB	4	177	366	1000	M10	10
90202	PSB	5	177	306	1000	M10	6
90203	PSB	5	177	366	1000	M10	8
90204	PSB	5	177	426	1000	M10	10
90205	PSB	6	177	342	1000	M10	6
90206	PSB	6	177	414	1000	M10	8
90207	PSB	6	177	486	1000	M10	10
90211	PSB	1A	127		1000	M10	6
90212	PSB	1A	127		1000	M10	8
90213	PSB	1A	127		1000	M10	10
90214	PSB	1B	127	152	1000	M10	6
90215	PSB	1B	127	164	1000	M10	8
90216	PSB	1B	127	176	1000	M10	10
90217	PSB	2	127	188	1000	M10	6
90218	PSB	2	127	212	1000	M10	8
90219	PSB	2	127	236	1000	M10	10
90220	PSB	3	127	224	1000	M10	6
90221	PSB	3	127	260	1000	M10	8
90222	PSB	3	127	296	1000	M10	10
90223	PSB	4	127	260	1000	M10	6
90224	PSB	4	127	308	1000	M10	8
90225	PSB	4	127	356	1000	M10	10
90226	PSB	5	127	296	1000	M10	6
90227	PSB	5	127	356	1000	M10	8
90228	PSB	5	127	416	1000	M10	10
90229	PSB	6	127	332	1000	M10	6
90230	PSB	6	127	404	1000	M10	8
90231	PSB	6	127	476	1000	M10	10

The above mentioned data are only for information purposes and are without a guarantee. The customers is required to check from time to time if the product is suitable for the required application. Upon request miled bus bar supports and other from GPO-3 extracted details can be supplied in this instance drawings are to be submitted.
 Type tested according to IEC 61439-2-2011-08, EN 61439-2-2021-06 with practically relevant fixing points and supporting widths.

Mounting material/ Threaded bolts

GB

Threaded bolt



Art.-no.	Pac (pcs.)	Art-group	For thread	L (mm)
90272	100	GB	M4	15
90273	100	GB	M4	16
90274	100	GB	M4	18
90275	100	GB	M4	20
90276	100	GB	M5	20
90277	100	GB	M5	22
90278	100	GB	M5	27
90279	100	GB	M5	30
90280	100	GB	M6	18
90281	100	GB	M6	20
90282	100	GB	M6	25
90283	100	GB	M6	27
90284	100	GB	M6	33
90285	100	GB	M6	35
90286	100	GB	M8	20
90287	100	GB	M8	23
90288	100	GB	M8	25
90289	100	GB	M8	30
90290	100	GB	M8	33
90291	100	GB	M8	35
90292	100	GB	M8	38
90293	100	GB	M8	50
90294	100	GB	M10	30
90295	100	GB	M10	35
90296	100	GB	M10	38
90297	100	GB	M10	40
90298	100	GB	M10	45
90299	100	GB	M10	50
90300	100	GB	M12	30
90301	100	GB	M12	50
90326	100	GB	M16	40
90327	100	GB	M16	60

Hexagon screw

M10 with nut and washer



Art.-no.	Pac (pcs.)	Art-group	For thread	L (mm)
90309	100	SKS	M10	60
90310	100	SKS	M10	80
90311	100	SKS	M10	70
90312	100	SKS	M10	90
90313	100	SKS	M10	100
90314	100	SKS	M10	110
90315	100	SKS	M10	140
90316	100	SKS	M10	150
90317	100	SKS	M10	160

Threaded bolt

M10 complete with nut and washer

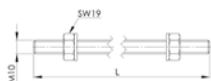

Art.-no.	Pac (pcs.)	Art-group	For thread	L (mm)
90318	100	GB	M10	194
90319	100	GB	M10	230
90320	100	GB	M10	242
90321	100	GB	M10	270
90322	100	GB	M10	290
90323	100	GB	M10	350
90324	100	GB	M10	410
90325	100	GB	M10	1000

Hexagon spacer in brass

SK



Art.-no.	Pac (pcs.)	For thread	H (mm)	SW* (mm)
90330	100	M4	15	7
90331	100	M4	20	7
90332	100	M4	25	7
90333	100	M4	30	7
90334	100	M4	50	7
90335	100	M4	70	7
90336	100	M5	90	7
90337	100	M5	15	8
90338	100	M5	20	8
90339	100	M5	25	8
90340	100	M5	30	8
90341	100	M5	50	8
90342	100	M5	70	8
90343	100	M5	90	8
90344	100	M6	15	10
90345	100	M6	20	10
90346	100	M6	25	10
90347	100	M6	30	10
90348	100	M6	50	10
90349	100	M6	70	10
90350	100	M6	90	10
90351	100	M8	15	13
90352	100	M8	20	13
90353	100	M8	25	13
90354	100	M8	30	13
90355	100	M8	50	13
90356	100	M8	70	13
90357	100	M8	90	13

*sw=wrench width

Bus bar support L



Support L185/1

Art.-no. 90392

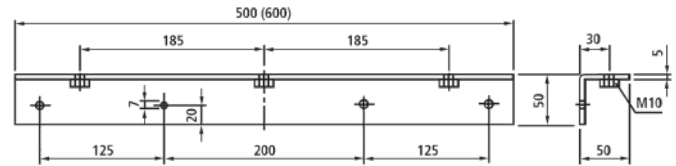

Support L185/2 (2 x M10 each phase)

Art.-no. 90395

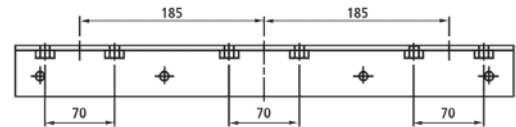

Bus bar supports in general

Characteristics of the raw material (GRP-profile, hot hardened)

- Temperature range -40°C bis +130°C
- Operating AC voltage 1000 V
- Continuous current

L/Z 280 mm	2500 A
L/Z 500 mm	4000 A
- Phase clearance

L/Z 280 mm	100 mm
L/Z 500 mm	185 mm
- Form stability DIN 53462 °C > 200
- Natural density DIN 53479 gr/cm² ca. 1,7
- Fire resistance UL 94 HB
- Discharge resistance DIN 53481 kV/cm 10
- Resistance voltage tracking DIN IEC 112 CTI 600
- Specific flow resistance DIN 53482 Ohm x cm 1012

All bus bars are type tested acc. to VDE 0660, part 500

- Torque for M10: approx. 4.5 Nm
- Copper bus bar 10 mm thick made of copper F30 not nickel-plated

Support L100

Art.-no. 90391

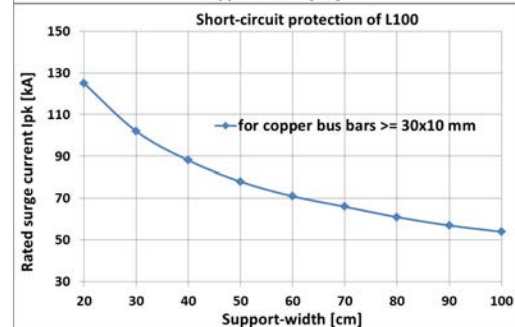
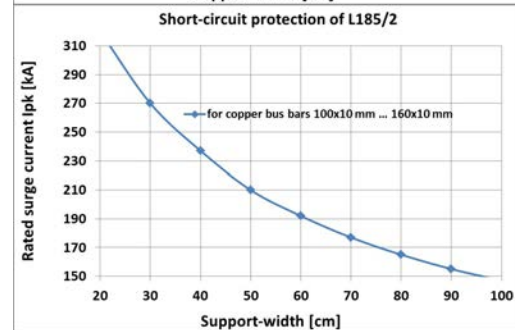
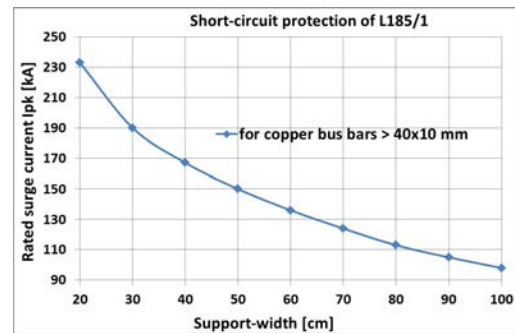
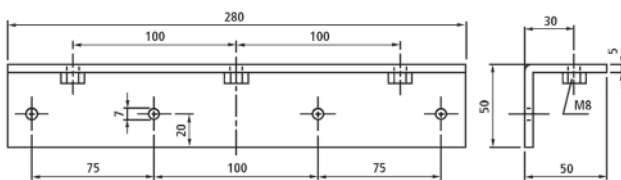

Type	Art.-no.	Pac (pcs.)	Art.-group	Length [mm]	Profile [mm]	Bore [mm]	Thread [mm]	Color
L100	90391	1	L	280	50/50	7	M8	grey
L185/1	90392	1	L	500	50/50	7	M10	grey
L185/2	90395	1	L	500	50/50	7	M10	grey

Bus bar support Z



Support Z185/1

Art.-no. 90382

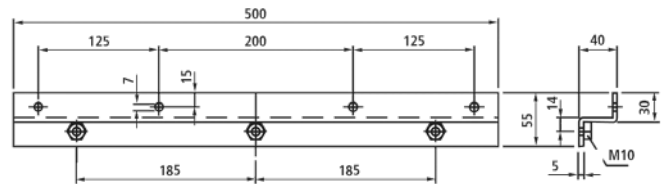

Support Z185/2 (2 x M10 each phase)

Art.-no. 90385

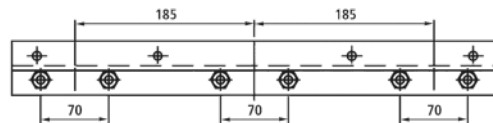

Bus bar supports in general

Characteristics of the raw material (GRP-profile, hot hardened)

- Temperature range -40°C bis +130°C
- Operating AC voltage 1000 V
- Continuous current

L/Z 280	2500 A
mm	
L/Z 500	4000 A
mm	
- Phase clearance

L/Z 280	100 mm
mm	
L/Z 500	185 mm
mm	
- Form stability DIN 53462 °C > 200
- Natural density DIN 53479 gr/cm² ca. 1,7
- Fire resistance UL 94 HB
- Discharge resistance DIN 53481 kV/cm 10
- Resistance voltage tracking DIN IEC CTI 600 112
- Specific flow resistance DIN 53482 Ohm x cm 1012

All bus bars are type tested acc. to VDE 0660, part 500

- Torque for M10: approx. 4.5 Nm
- Copper bus bar 10 mm thick made of copper F30 not nickel-plated

Support Z100

Art.-no. 90381

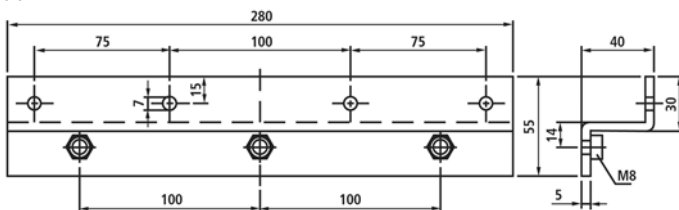

Type	Art.-no.	Pac (pcs.)	Art.-group	Length [mm]	Profile [mm]	Bore [mm]	Thread [mm]	Color
Z100	90381	1	Z	280	30/40/30	7	M8	grey
Z185/1	90382	1	Z	500	30/40/30	7	M10	grey
Z185/2	90395	1	Z	500	30/40/30	7	M10	grey

■ MADE
■ IN
■ GERMANY

- Current transformers for industry
- Current transformers for tariffs
- Accessories for current transformers
- Medium-voltage transformers

- Bus bar insulators / -supports
- Shunts
- Voltage transformers
- All current sensors
- Measuring transducers
- Energy meters with or without MID approval
- Accessories for energy meters
- Panel board heaters, filter fans, roof fans and control units



www.mbs-ag.com

MBS AG
Eisbachstraße 51 74429 Sulzbach-Laufen Germany
Phone: +49 7976 9851-0 Telefax: +49 7976 9851-90
info@mbs-ag.com www.mbs-ag.com

