



Safety and Installation Instructions. Please read before use!



Type VTLS

Low-voltage Voltage Transformer, Single-pole Insulated for indoor application

General: The low-voltage voltage transformer works on the principle of the inductive transformer. The secondary side is galvanically separated from the primary side. The instrument transformer is used in switchgear, switching device combinations and power distribution systems in connection with secondary devices (relay, energy meter, voltmeter indication instruments). The housing is made from polycarbonate. The operational specifications can be found on the rating plate.

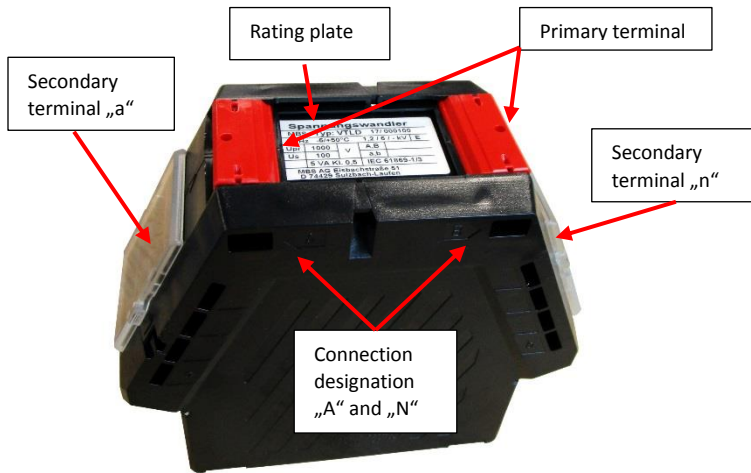
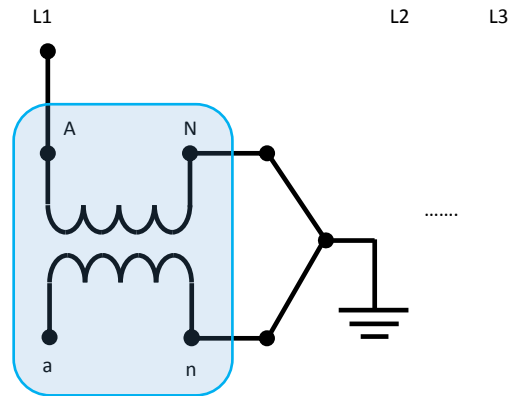

Figure: VTLS



Circuit diagram: Application of a VTLS

Unpacking

Check the instrument transformer for completeness and integrity. Pay attention to sharp edges on the housing. You could cut yourself. If the instrument transformer show any signs of external damage there is the risk of an electric shock when putting it into operation.

Storage

Store the voltage transformer at an ambient temperature from -20°C up to +80°C. The relative atmospheric humidity should be <95% a non-condensing.

Transport

The voltage transformer can be transported without any aids. If any damage occurs during the transportation please contact us directly.

Ensure a safe working environment during assembly, installation, commissioning, shut down and during inspection work on the electrical system

Assembly / Installation

For the next installation steps you must have the necessary expertise and know-how for electrical installation



Shut down the relevant electrical system before assembly. Otherwise there is the risk of suffering an **electric shock**.

- ▶ Mount the voltage transformer on a base with the provided foot mounting angles. Make sure that the mounting surface is even.
- ▶ Avoid mechanical tensions during operation. Make sure that no dynamic loads act on the transformer.



Do not short-circuit the secondary circuit of the voltage transformer under any circumstances. With short-circuited secondary winding, the voltage transformer will be thermally overloaded.

There is risk of death! The induced currents endanger the functional safety of the voltage transformer.

Initial operation

Assure yourself that the voltage transformer is mounted properly and the secondary and primary cables are connected correctly. Have you used the tightening torques as specified?

- ▶ In case of downstream grounding measures, ensure that you did not integrate a short-circuit loop.
- ▶ If you are unsure, please contact an experienced colleague or contact us directly.

Operation

- ▶ During Operation, do not touch the primary or secondary terminals. Make sure, that unauthorized persons or children have no access to the voltage transformer.
- ▶ You must not operate the instrument transformer with secondary short-circuit (refer to the safety instructions given *Assembly / Installation*).

Shutdown

Shut down the relevant electrical system. Ensure that the system stays de-energized while working on the voltage transformer.

Disassembling

Follow the work steps as described under *Shutdown*. Consider the safety instructions given in *Assembly / Installation* and then you can loose the secondary and primary terminals and the foot mounting angles.

Cleaning

Follow the instructions under *Shutdown*. Observe and follow the safety instructions in *Assembly / Installation*. The voltage transformer must not get in contact with fluids. The fluids can get into the housing. There is the risk of a short-circuit.

Maintenance

The voltage transformer is maintenance-free.

Disturbance

The voltage transformer cannot be repaired. If the voltage transformer is defective, please contact us.

Disposal

Dispose of the instrument transformer in accordance with the national provisions of the country in which you are operating it.

We do not assume any liability for incorrect or improper assembly and installation!