

# Operating instructions/ Installation instructions

Please keep!

## Low-voltage current transformer - Three-phase current transformer sets -

Series ASRD 14, ASRD 205.37, ASRD 310.37



**MBS AG**

**Eisbachstrasse 51  
74429 Sulzbach-Laufen,  
Germany**

**Tel. +49 7976 9851-0**

**Fax. +49 7976 9851-90**

info@mbs-ag.com • www.mbs-ag.com

**Before installation, commissioning, or operation of the device, read these instructions carefully and thoroughly.**

## **1. Safety instructions**



### **CAUTION**

The following items must be complied with:

- The applicable laws, standards, and provisions.
- The state of the technological art at the time of installation.
- The rules surrounding technology.
- The operating instructions.
- The fact that operating instructions can include only general instructions, and that these instructions must be complied with.
- Before commissioning the device, check it carefully for any damage possibly sustained during transport. In the event of mechanical damage, the device must not be put into operation.
- The devices described are designed for installation by qualified specialist electricians and must be installed only in electrical plant rooms or in closed housings. Any other use or failure to comply with these usage instructions will render the warranty/guarantee null and void.
- Devices must be installed only in dry, indoor spaces.
- Do not install on easily flammable materials.
- Operation with a rated current higher than that stated on the type plate can result in burns and overheating of the current transformer.

## 2. Functional description

Current transformers in the ASRD series are each 3 inductive single-wire current transformers operating on the transformer principle and combined into three-phase current transformer sets. They are used to adapt the primary measuring parameter to the input rated parameters of the connected measuring equipment.

As a result of the measuring principle used, these current transformers are suitable only for use on alternating current networks.

Current transformers of the ASRD series are maintenance-free.

## 3. Warning information



**WARNING**

Dangerous electrical voltage can cause electric shock and burns. Ensure that the information on the type plate and in the "Technical data" under Point 6 matches the operating parameters of the system.

Before starting any installation work, disconnect the system from the power supply!



**WARNING**

If there is an unladen (open) secondary circuit in the current transformer, high voltages will be induced at its secondary terminals. The voltages that occur there represent a danger to persons and to the functional safety of the current transformer.

**It is essential to avoid "open mode", i.e. operation of the current transformer without secondary circuitry.**

## 4. Installation

- Ensure a safe working environment during assembly, maintenance and installation work. Interrupt the power supply to the primary conductors and secure it against being inadvertently switched back on.
- Install the current transformer on the primary conductors.
- To do this, lead the primary conductors (Cu-rail or round conductor) through the window openings of the current transformer housing.  
The window openings are marked “K-P1” and “L-P2”, and also “L1”, “L2”, “L3” (for the individual phases).
- For types ASRD 205.37 and ASRD 310.37, the devices can be attached either directly on the primary conductors, or else on a mounting plate. To do this, use the attachment materials included in the scope of delivery.  
Direct attachment to the primary conductors is achieved by screwing the fastening screws included in the accessory pack into the screw bosses located in the transformer housing. Installation on the mounting plate is achieved using the foot mounting bracket also included in the accessory pack.
- Type ASRD 14 is intended for snap-on mounting to a 35 mm DIN top-hat rail.
- Establish the secondary connections. Comply with the markings on the secondary terminals.

### 4.1. Measuring circuit

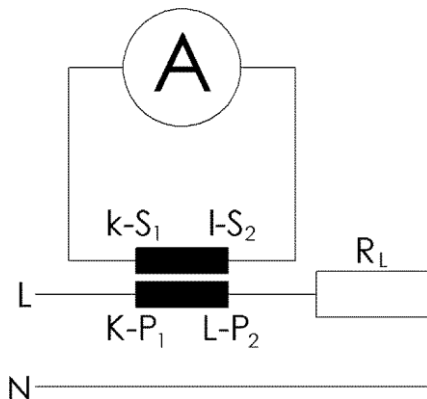

## 4.2. Multi-phase counter circuit

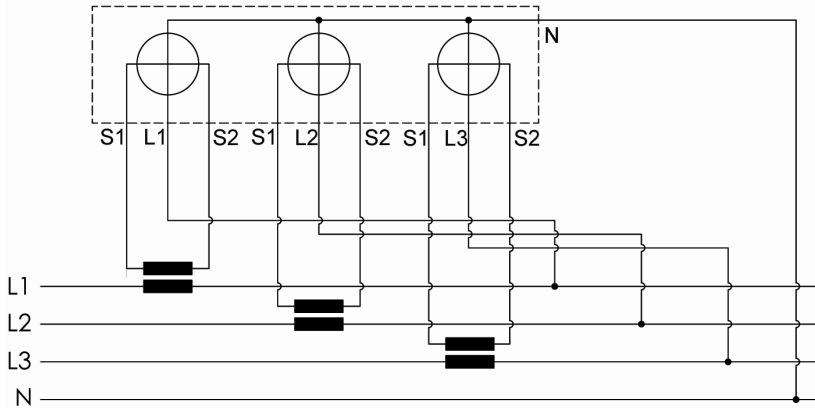

## 4.3. Installation instructions

Installation of the fastening screws for ASRD 205.37, ASRD 310.37

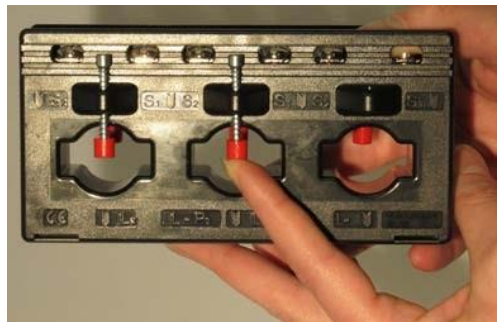

Installation onto copper rail or round conductor for ASRD 205.37, ASRD 310.37

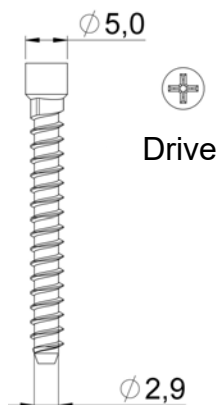
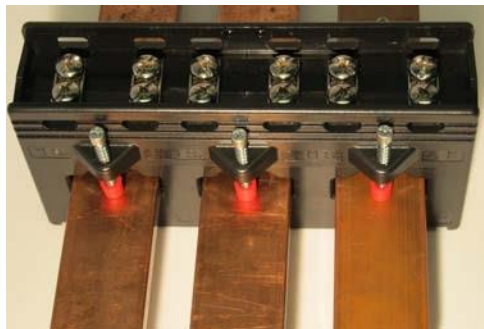

Tightening torque of fastening screw: 0.5 Nm

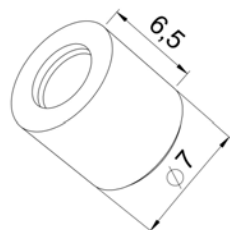

Installation onto mounting plate for ASRD 205.37

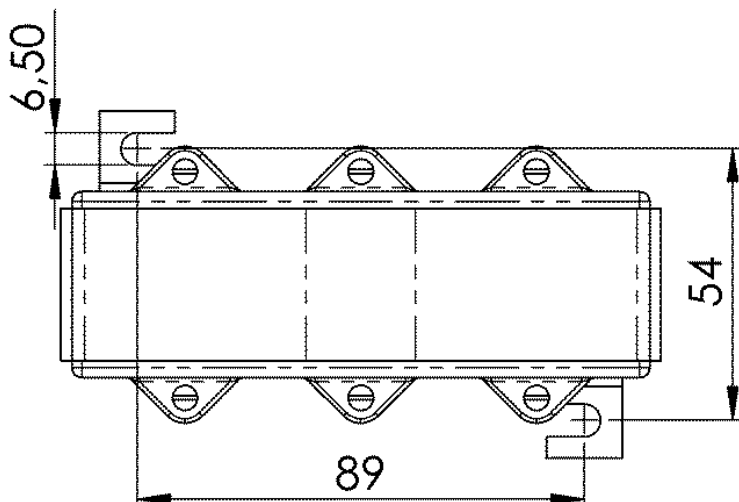

## Installation onto mounting plate for ASRD 310.37

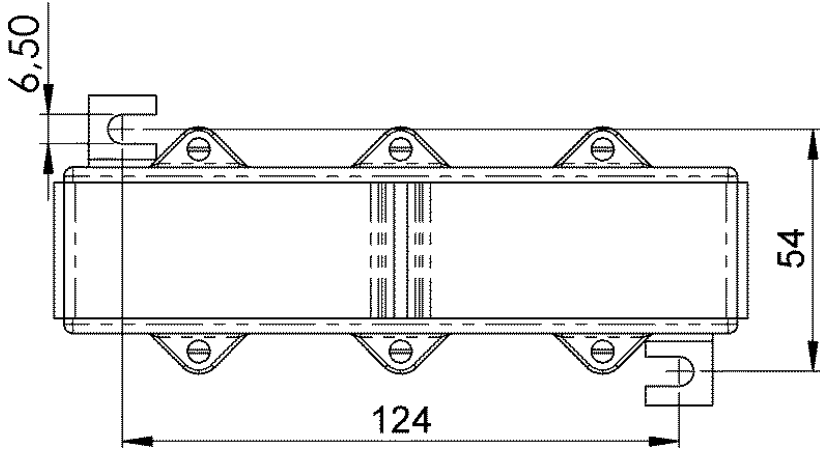

## 5. Application example



## 6. Technical data (for exact details, see type plate)

### 6.1. General technical data Input

Primary rated current $I_{pr}$ :	See under 6.2
Thermal rated continuous current $I_{cth}$ :	$1.0 \times I_{pr}$ (100%)
Rated thermal short-term current $I_{th}$ :	$60 \times I_{pr}/1s$
Rated surge current $I_{dyn}$ :	$2.5 \times I_{th}$
Rated frequency $f_R$ :	50 ... 60 Hz

### Output

Secondary rated current $I_{sr}$ :	5 A or 1 A
Accuracy class (type-dependent):	0.5 ... 1
Rated load $S_r$ (type-dependent):	1 ... 5 VA
Overcurrent limiting factor FS (type-dependent):	FS5

### Operating conditions

Ambient temperature:	-5 ... +50 °C
Storage temperature:	-25 ... +70 °C
Relative humidity (non-condensing):	5 ... 85 %
Permitted altitude for operation:	Up to 2000 m

### Insulation properties:

Rated insulation level $U_m$ (in accordance with IEC 61010-1 under the following conditions: - Overvoltage category III - Degree of contamination 2 - Heterogeneous electric field):	0.72/3/- kV
Insulation material class:	E

### Safety

Protection category:	IP20
Housing material:	PC
UL housing classification:	UL94-V2



## Connection

Conductor feedthrough of primary conductor:	see 6.2
Connection technology, secondary ASRD 14:	Cage clamps nickel-plated
Connection cross-section:	max. 4 mm <sup>2</sup> with wire end ferrule
Stripping length:	10 mm
Tightening torque:	0.8 ... 1.2 Nm
Connection technology, sec. ASRD 205.37, 310.37: terminals	Secondary nickel-plated
Connection cross-section:	max. 4 mm <sup>2</sup> with wire end ferrule, 6 mm <sup>2</sup> solid
Tightening torque:	max. 2 Nm

## Applied standards

IEC 61869-1  
IEC 61869-2  
EN 61010-1

The most recent edition of the documents specified,  
including all modifications, applies.

## 6.2. Technical data, type-related

### 6.2.1 Summary

Transformer type	ASRD 14	ASRD 205.37	ASRD 310.37
Primary rated current [A]	50 ... 150	100 ... 250	250 ... 600
<b>Conductor feedthrough, primary conductor</b>			
Rail [mm]	---	20 x 5	30 x 10
Round conductor [mm]	13.5	18	22
<b>Dimensions</b>			
Width [mm]	105	115	150
Height [mm]	90	65	75
Total depth [mm]	54	55	55

## 6.2.2 ASRD 14

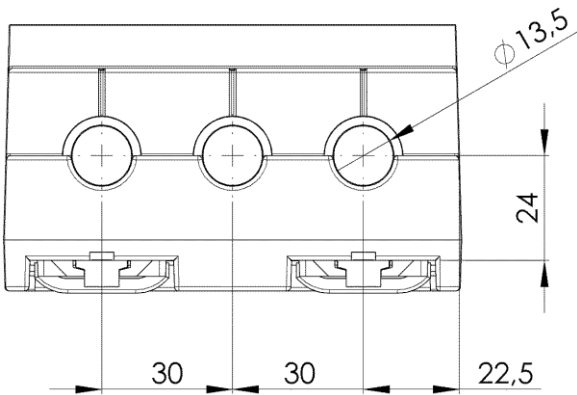
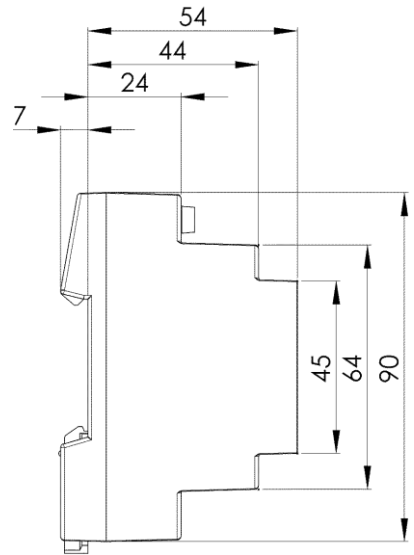
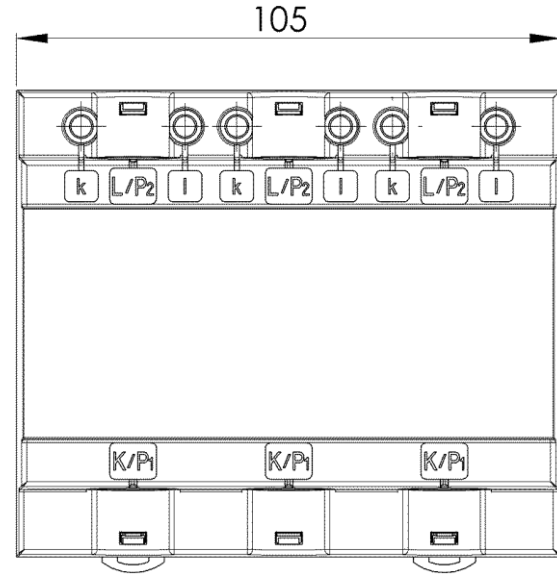

### 6.2.3 ASRD 205.37

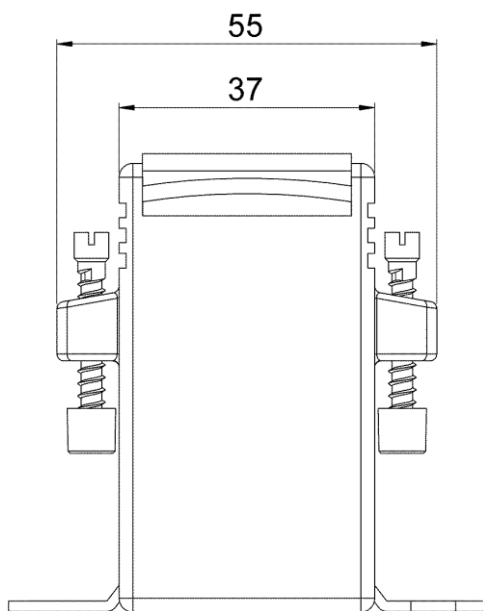
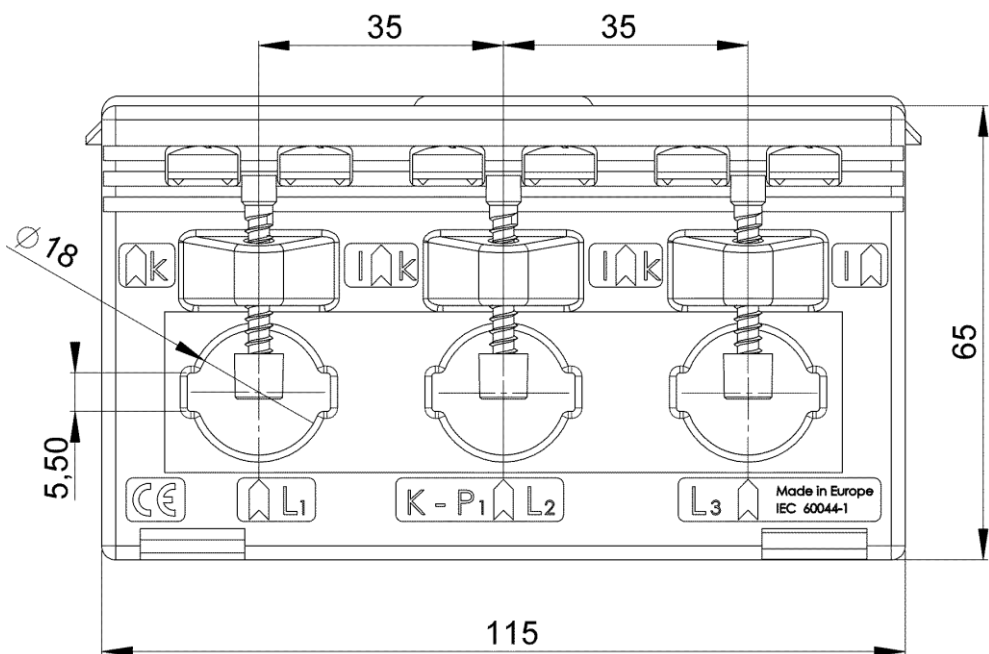

## 6.2.4 ASRD 310.37

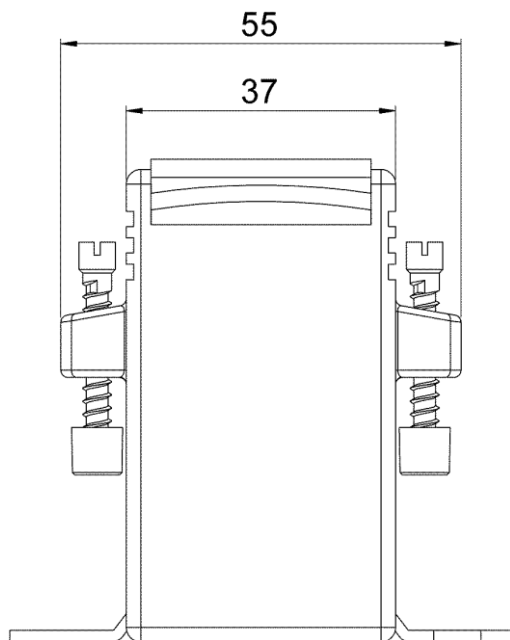
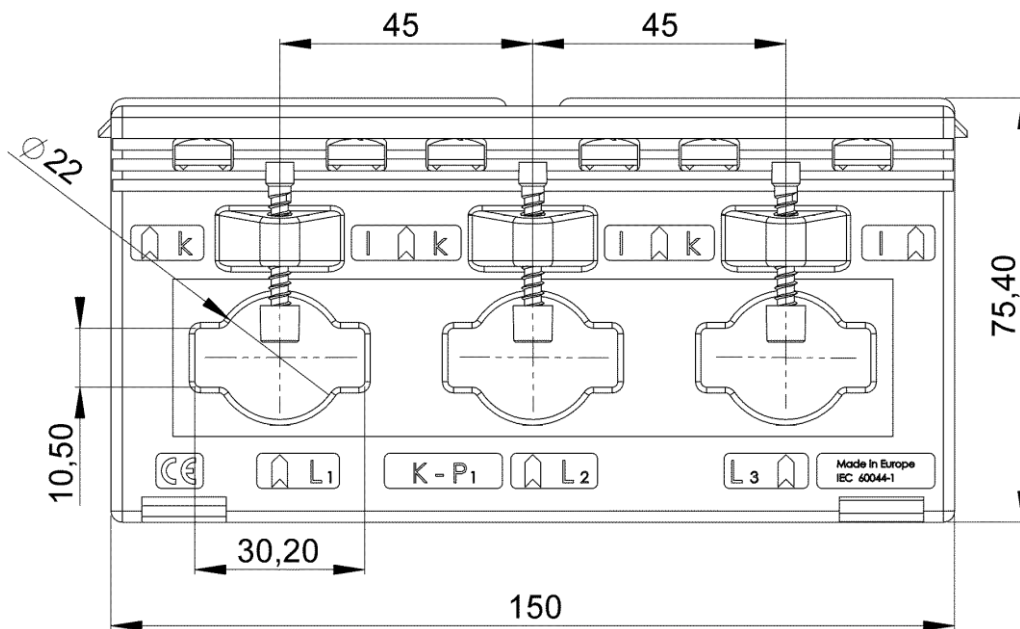

## 6.3. Type plate markings

### 6.3.1 ASRD 14

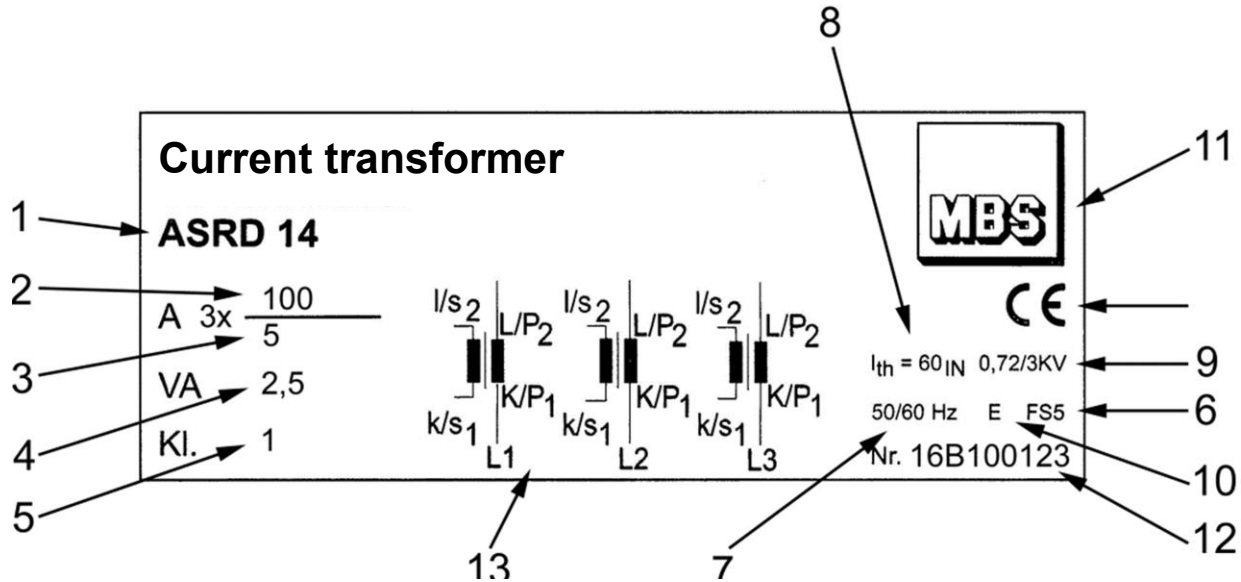

- 1 Type designation
- 2 primary rated current  $I_{pr}$
- 3 secondary rated current  $I_{sr}$
- 4 Rated load  $S_r$
- 5 Accuracy class
- 6 Overcurrent limiting digit
- 7 Rated frequency

- 8 Rated thermal short-term current  $I_{th}$
- 9 max. operating voltage  $U_m$ /rated insulation level
- 10 Insulation class
- 11 Manufacturer
- 12 Production number
- 13 Connection diagram

### 6.3. Type plate markings 6.3.2 ASRD

#### 205.37, ASRD 310.37

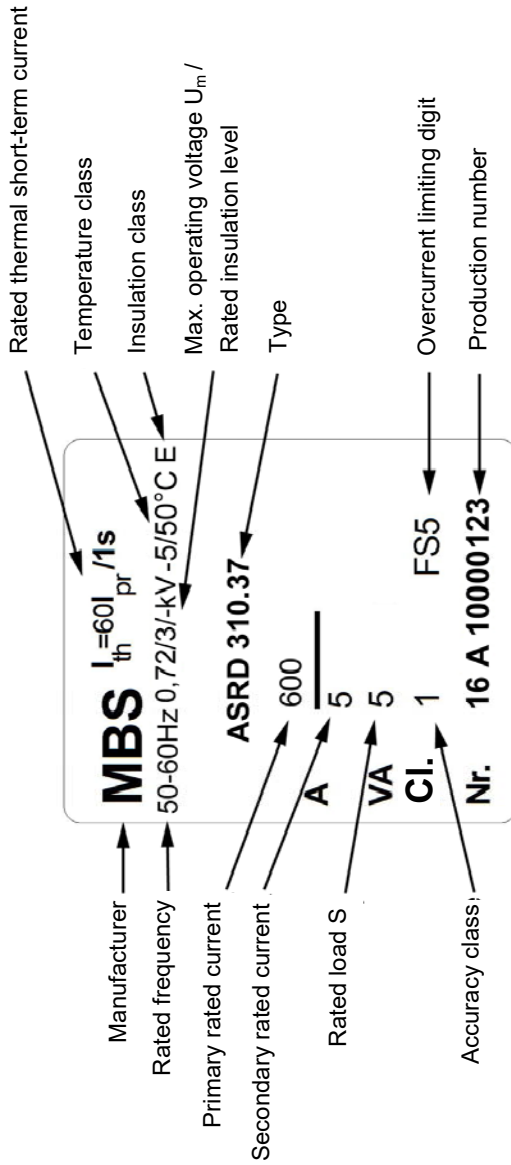



This product was developed and produced in accordance with the applicable standards (IEC 61010, IEC 61869) and complies with the requirements of the Low Voltage Directive 2014/35/EU.



MBS AG hereby declares that it uses components only from qualified manufacturers in its products, the specifications of which satisfy or exceed the requirements of the EU directive on the restricted use of certain hazardous substances.



Once the product has reached the "end of its useful life", it must be recycled. Do not dispose of in domestic waste.  
If necessary, ask a waste consultant.



# MBS AG

Eisbachstrasse 51 • 74429 Sulzbach-Laufen • Germany  
Telephone: +49 7976 9851-0 • Fax: +49 7976 9851-90  
info@mbs-ag.com • www.mbs-ag.com