

# Residual Current Monitoring

acc. IEC 62020



[www.mbs-ag.com](http://www.mbs-ag.com)





**We design  
the future for you  
TODAY !**



## Highly flexible Residual Current Monitor of Type B/B+ for measuring DC and AC residual currents up to 100 kHz, with analog 4-20 mA and relay output.

User selectable Frequency range, Integration time and Rated residual operating current.



### Features & Highlights:

70 mm primary cable / busbar aperture

DC and AC residual current measurement of Type B/ B+ in the range 0-2 Arms up to 100 kHz

User selectable:

- Frequency range
- Integration time
- Rated residual operating current

Analog 4-20 mA and relay output

Fluxgate current measurement technology with fixed excitation frequency for enhanced accuracy and stability

### Applications:

Residual current monitoring in industry

Condition-based monitoring of insulation health

Replacement of / supplement to compulsory

High voltage insulation testing

Scheduling of planned factory maintenance

DC power systems (UPS, PV, LED lighting...)

High frequency loads (SMPS, Motor drives...)

Mission critical (Data centers, Medical ...)



### Background

Residual currents (aka Earth fault currents, Insulation leakage currents) are unique measure for the state of the insulation of the electrical power system and its need for maintenance & repair to avoid nuisance shutdowns. Monitoring of the residual currents in real-time in a power system gives the possibility to evaluate the health of the electrical insulation based on the actual value measured, while the long-term development of the residual current value can be used for planning maintenance to avoid significant insulation deterioration. In this way, Residual Current Monitors (RCMs) used in a Condition-based Monitoring scheme as per Industry 4.0 standards can ensure early fault detection and increase the availability of the power system at much lower cost than regular, expensive and time consuming high voltage insulation testing.

This fact is set out in the standard IEC 60365-6 (2016-04):

Where a circuit is permanently monitored by an RCM in accordance with IEC 62020 ...it is not necessary to measure the insulation resistance if the function of the ... RCM is correct.

Residual currents in electrical power systems can have multiple sources: insulation faults, insulation leakage currents, capacitive displacement currents, EMC filter leakage currents etc. While some of these contributing residual currents are normally present due to material physics when subjected to high or alternating voltages, other contributors are sign of deteriorating insulation which can produce abnormal heat dissipation, short-circuits and in worst case fire and danger to personal safety. Proliferation of DC loads (e.g. LED lighting, DC motor drives, 48Vdc bus systems etc.), DC distributed generation (e.g. PV systems, UPS, batteries etc.) as well as high-frequency converters (e.g. SMPS, motor drives etc.) in industrial environments makes it increasingly difficult to measure reliably insulation faults with traditional RCMs designed for AC 50/60Hz with limited measurement bandwidth. It is the experience of many installers around the world that in order to make the residual current protection work not only now but also in the future with extensions of existing plants, it is necessary for the end-user to have the possibility to select from several residual current limits, different frequency bandwidths and sensitivity levels.



## General description

Residual Current Monitors (RCMs) are used for monitoring of the residual currents in electrical power systems without the need for fast system shutdown. The RCM of Type B/B+ can measure DC and AC residual currents at frequencies of up to 100 kHz, which makes it compatible to multitude of industrial applications, loads and generation sources. With its user selectable settings, this RCM offers flexible platform for residual current measurement which fits every possible usage both at the moment the industrial plant is designed, but also in case of extensions with new modern loads operating with DC voltages or at high switching frequencies which increase the amount of leakage current in the system.

The RCM product features an analog 4-20 mA output which represents the real-time True RMS (TRMS) value of the measured residual current for interfacing to e.g. a PLC. Additionally a free potential relay output (NO / NC) with user selectable rated residual current limit can be used for warning or even system shutdown when the TRMS residual current measurement has exceeded the preset value. The status of the relay output is replicated to a LED for visual indication on the device itself. Built-in test button and external test button input are provided for regular testing of the RCM as per applicable product standards. Only a single 24 Vdc power supply should be provided for powering the RCM.

Intended for use in Single-phase and 3-wire & 4-wire Three-phase systems.

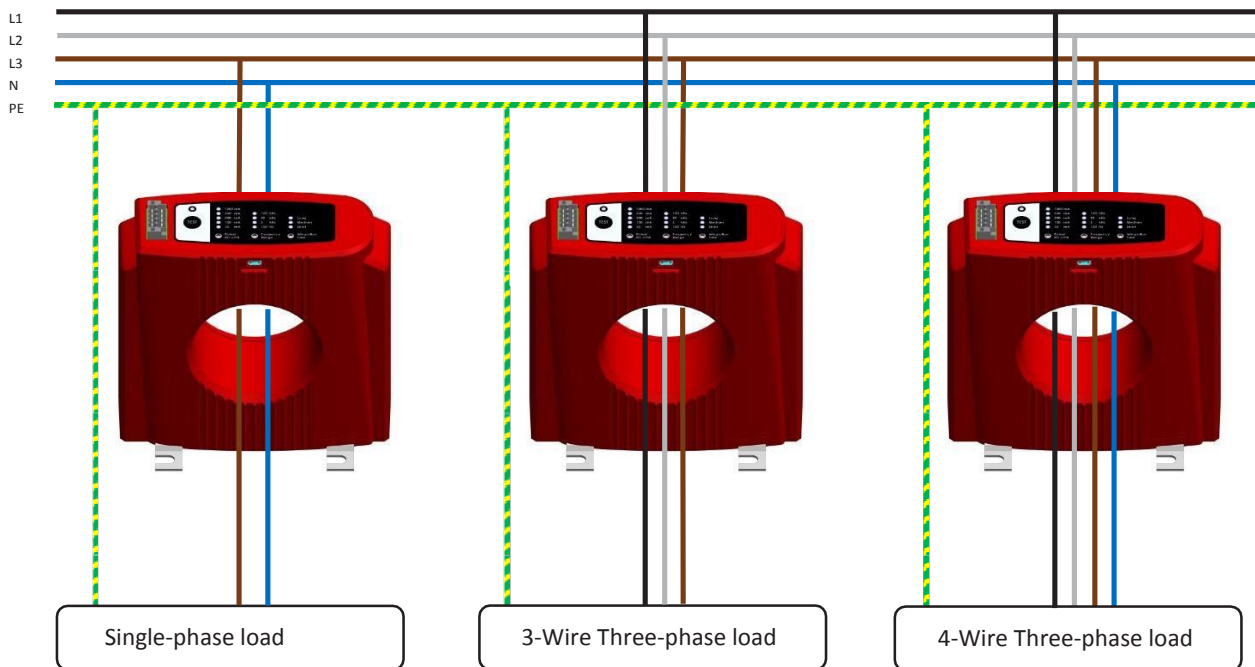

### Connector

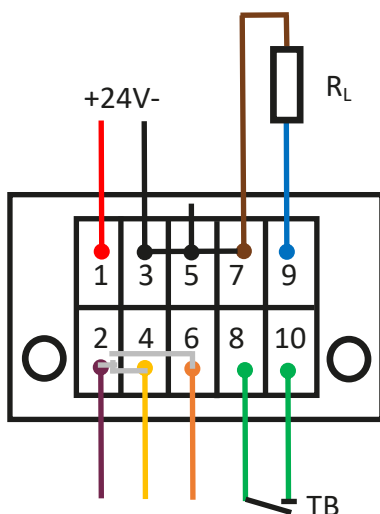

### Pinout:

- 1: 24 Vdc
- 2: Relay common
- 3: 0Vdc
- 4: Relais NC contact, alarm: closed
- 5: 0Vdc
- 6: Relais NO contact, alarm: open
- 7: 0Vdc
- 8: External Test button, contact 1
- 9: Analog 4-20mA output
- 10: External Test button, contact 2

## Functional description

The Residual Current Monitor RCMB 70 senses the instantaneous, real-time value of both DC and AC residual current using the built-in transducer head with integrated balanced Flux-gate detector. For the purpose of functional protection and especially fire protection of the electrical power system, the RCM implements the True RMS (TRMS) value of the residual current which corresponds to the amount of heat dissipated in the insulation. In order to provide high level of flexibility in the RCM usage and fit to as many potential applications as possible, this RCM is equipped with three user-selectable parameters which affect the final TRMS value indicated at the analog 4-20mA output as well as the relay output and status LED.

The "Frequency range (FR)" parameter limits the frequency bandwidth of the measured residual currents. After the frequency range of interest have been selected, the "Integration time (IT)" parameter determines the length of the integration window for the TRMS value. Finally the TRMS value is scaled according to the selected "Rated RC limit" into two different ranges (details in the electrical specification tables). After these intermediate steps, the TRMS value of the residual current is ready to be sent out to the analog 4-20 mA output. The behavior of the relay output and status LED is though influenced by couple of extra processing blocks, as described below.

The "Rated RC limit (RL)" sets the level at which, when violated by the Weighted TRMS, the relay output and status LED will toggle the state. Weighted TRMS is obtained from the TRMS value by applying a weighting filter which attenuates the residual currents with higher frequencies while passing entirely the low frequency residual currents, as per applicable product standards. The reason for this choice is that higher values of high-frequency residual currents appear naturally in switch-mode power converters when fast changing voltages are applied to e.g. cable insulation, output dv/dt filters, input EMC filter and Y capacitors to ground. In order to have a very precise output, the measured range of the residual current is related to the Rated RC limit.

Rated RC Limit (RL)	Measured Current RCMB70	Analog 4-20 mA DC output
30, 100 and 300 mA	0 - 4 mA	4 mA (0 A) - 20 mA (400 mA)
500 and 1,000 mA	0 - 2,000 mA	4 mA (0 A) - 20 mA (2,000 mA)

Decision on relay output status is done with a comparator having a hysteresis, meaning that after activation of the relay the residual current TRMS value needs to reduce by a certain hysteresis before the relay output is deactivated. In case of repetitive activation & deactivation of the relay, it is latched to activated state and Test button needs to be pressed for at least 3s to reset.

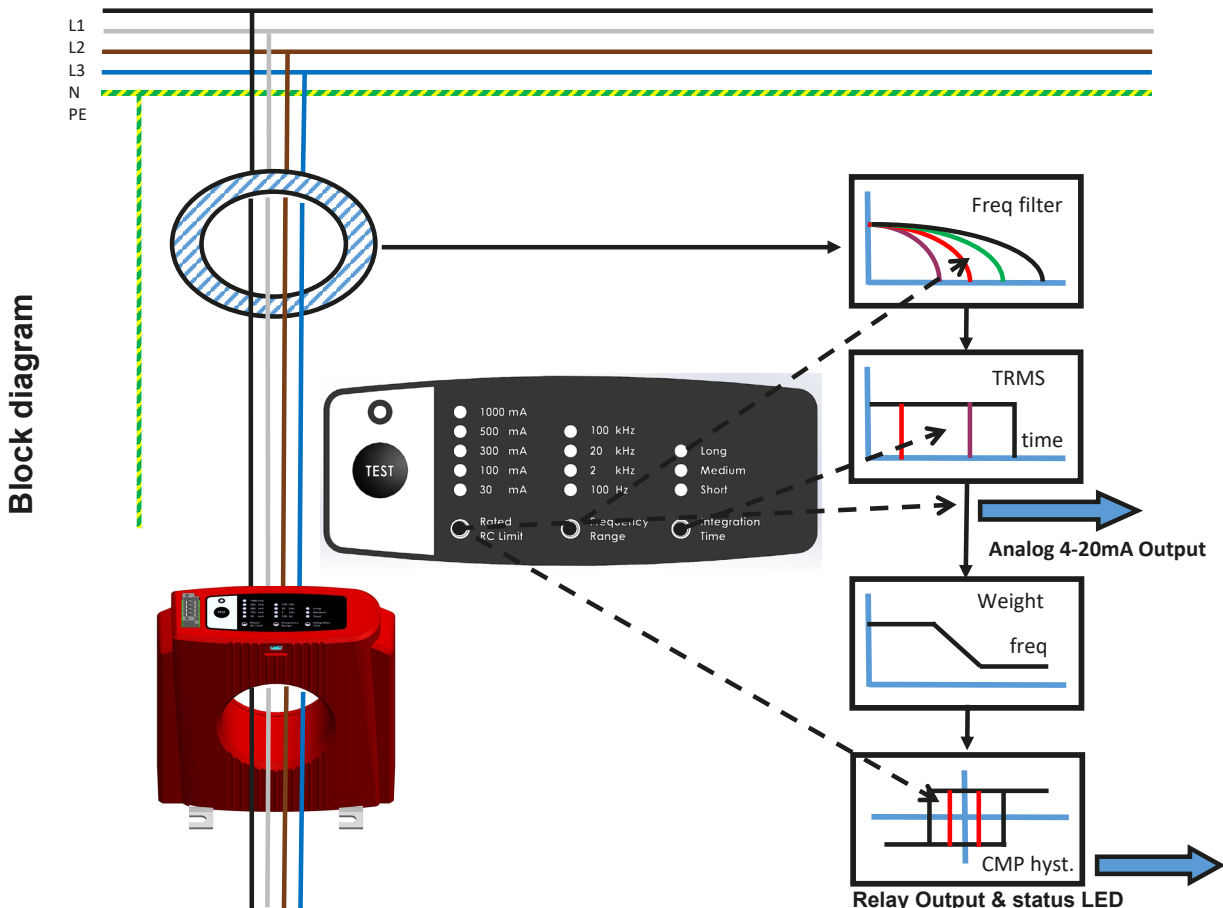

## User interface description

This RCM product features three user selectable parameters, each with the choice of selecting 3-5 different values. The simple and intuitive user interface can be found on the top of the RCM and is used for configuring the RCM with three buttons located below the surface level. These buttons can only be operated with a tool which prohibits unintentional and unauthorized access, as per applicable product standards. Interface features furthermore a Test button and status LED for visual indication.

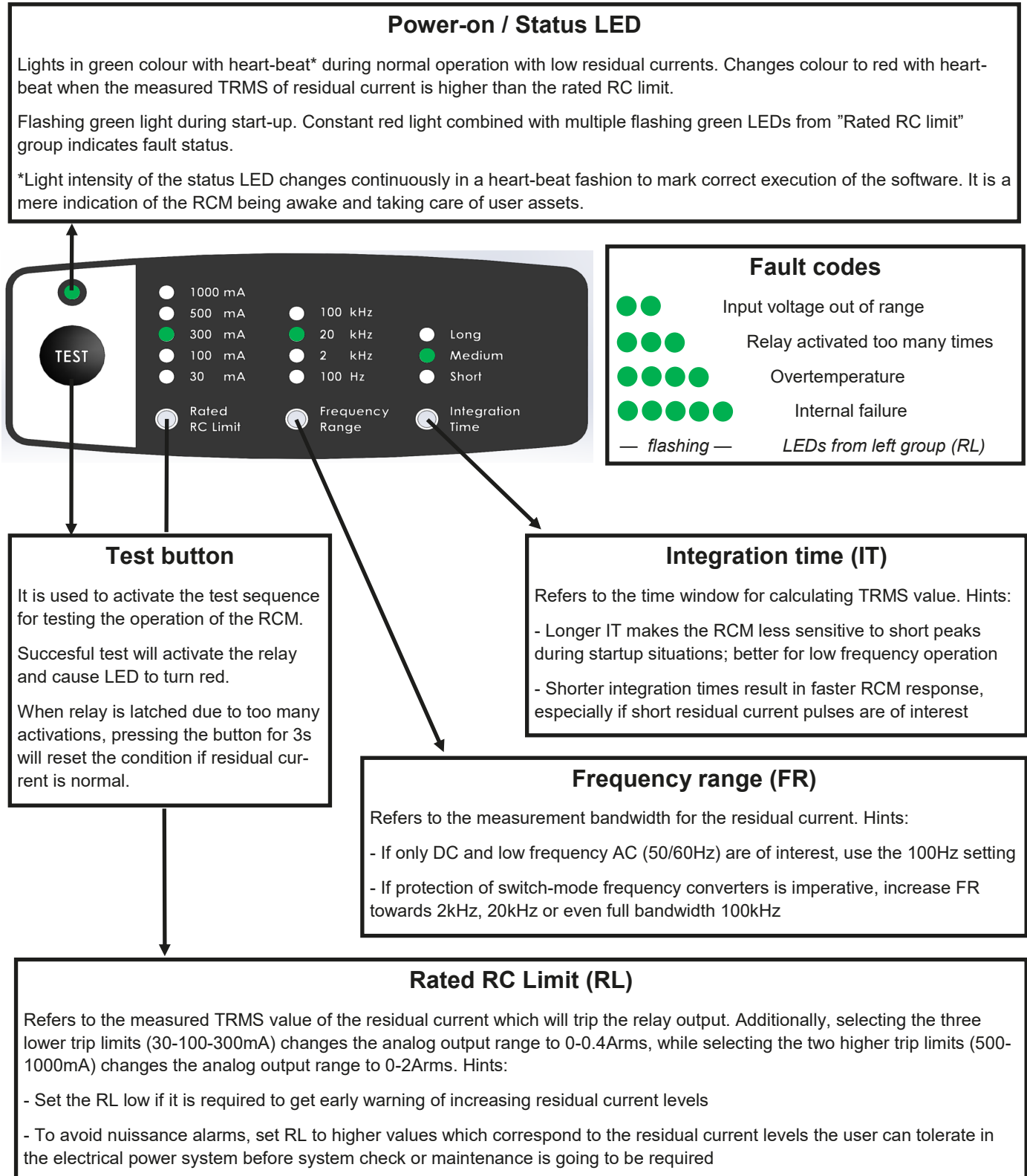

# Real-life examples of residual currents

Typical residual currents in a motor drive with frequency converter

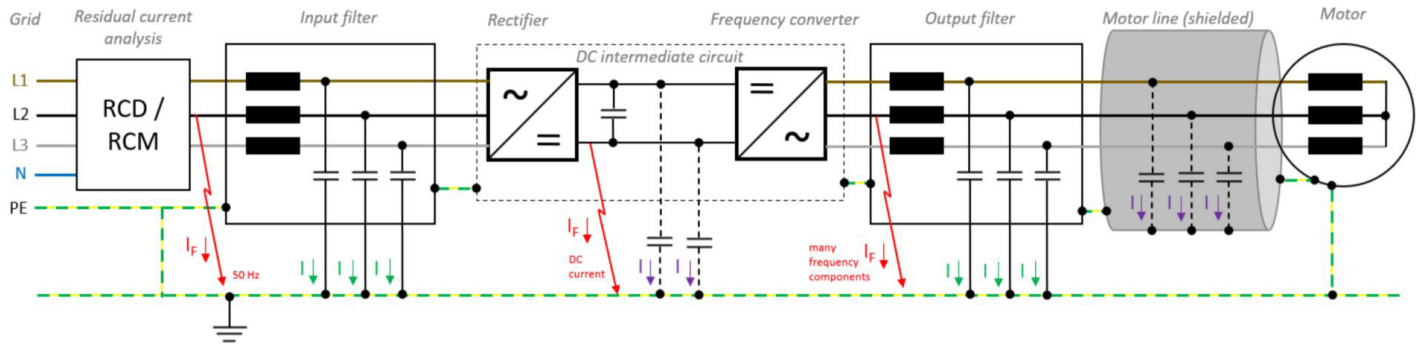

- $\downarrow$  = residual current due to parasitic capacitances
- +  $\downarrow$  = residual current due to capacitive filter

---

- = constant system-related residual current
- +  $I_F \downarrow$  = leakage current / fault current

---

- = measured total residual current of the RCM device

**Sample:**  
 System-related residual current of the plant 250 – 300 mA  
 Fire protection RCD is triggered under 300 mA  
 Alarm threshold 1: 400 mA (Pre-alarm)  
 Alarm threshold 2: 600 mA (shutdown of the plant)

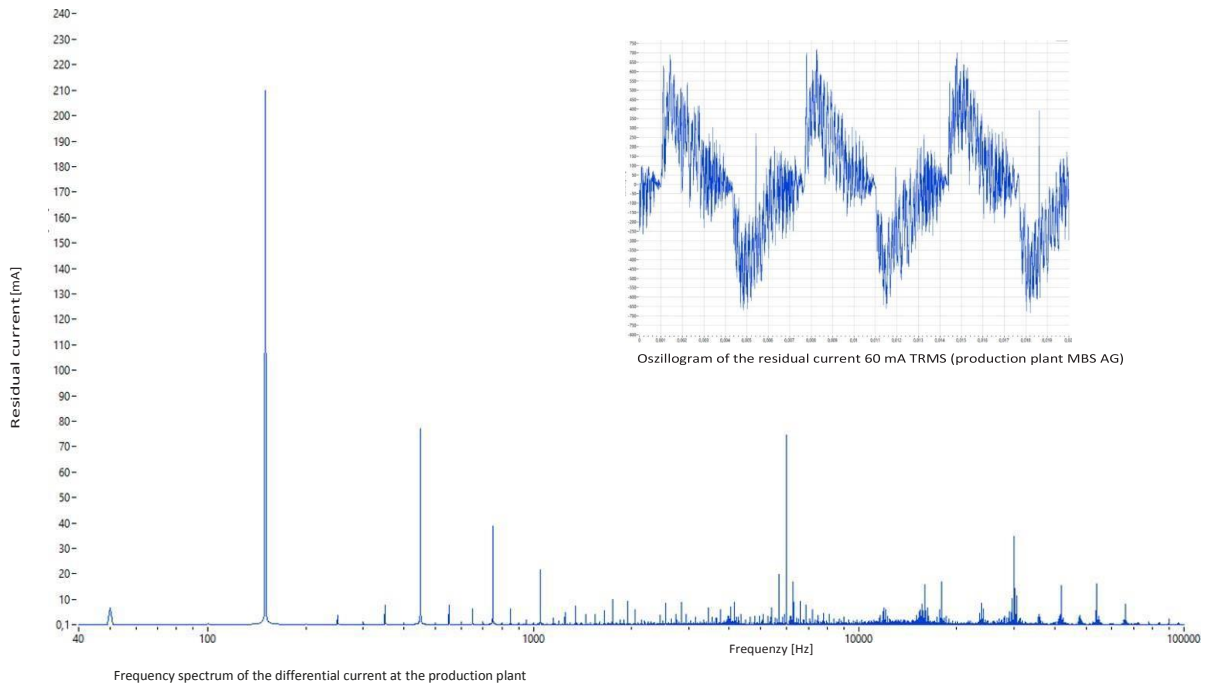

# Electrical specifications

## Primary monitored circuit

Parameter	Symbol	Value
Rated voltage of monitored circuit	$U_n$	0-690 vrms
Rated frequency range of monitored circuit	$f_n$	50 / 60 Hz
Applicable operating frequency of monitored circuit	$f_{aop}$	0-400 Hz
Rated primary current	$I_n$	100 A ( $I_{\Delta n}=30$ mA) 300 A ( $I_{\Delta n}=100-1000$ mA)
Max. non-tripping overcurrent	$I_{max}$	600 A ( $I_{\Delta n}=30$ mA) 1800 A ( $I_{\Delta n}=100-1000$ mA)
Thermal rated short-time (10ms) withstand residual current	$I_{\Delta th}$	200 A
Thermal rated continuous withstand residual current	$I_{\Delta cth}$	100 A
Rated impulse residual current	$I_{\Delta dyn}$	10 kA
Rated insulation voltage	$U_i$	700 V
Impulse withstand voltage	$U_{imp}$	8 kV
Oversvoltage category	OVC	IV
Pollution degree	PD	3

## Analog current interface 4-20mA

Parameter	Symbol	Value
Current output 0-0.4 Arms / 0-2 Arms	$I_{out}$	4-20 mAdc
Current output at 0% $I_{\Delta n}$	0%	4-4.2 mAdc
Current output at 0.4 Arms / 2 Arms	100%	19-21 mAdc
Peak-to-Peak noise	pk-pk	$\leq 0,25\%$
Resolution	$Res_{out}$	0,01 mA
Short-circuit current	$I_{sc,out}$	$< 25$ mAdc, SC-proof
Maximum total load resistance / apparent ohmic resistance with cable	$Rt_{max}$	$\leq 900 \Omega$
Typical load resistance	$R_{typ}$	250 $\Omega$
Voltage at open terminals	$U_{oc,out}$	24 Vdc
Response time 1x $I_{\Delta n}$ , step response 10-90%	$t_{10-90\%}$	$\leq T_i$
Response time 1x $I_{\Delta n}$ , step response 0-50%	$t_{0-50\%}$	$\leq T_i/2$
Response time 5x $I_{\Delta n}$ , step response 10-90%	5x $t_{10-90\%}$	$\leq T_i/30$
Response time 5x $I_{\Delta n}$ , step response 0-50%	5x $t_{0-50\%}$	$\leq T_i/50$

## External Test and Reset button

Parameter	Symbol	Value
Cable length for external Test & Reset key	$L_{tk}$	0-10 m
Short-circuit current	$I_{sc,tk}$	$< 4$ mAdc, SC-proof
Voltage at open terminals	$U_{oc,tk}$	24 Vdc



### CAUTION:

- PLEASE IMPERATIVELY RESPECT CONNECTION POLARITIES TO PREVENT DESTRUCTION OF THE RESIDUAL CURRENT MONITOR
- PLEASE ENSURE ADEQUATE CURRENT AND VOLTAGE RATING OF POWER SUPPLY TO AVOID MALFUNCTION

## Residual current characteristics

Parameter	Symbol	Value
Rated relay output residual current at 50/60Hz – user selectable	$I_{\Delta n}$	30 mA-100 mA - 300 mA-500mA - 1000mA
Residual current frequency range – user selectable	$f_{\Delta n}$	DC-100 Hz*, 2 kHz, 20 kHz und 100 kHz
Relay output residual operating current at 50/60 Hz	$I_{\Delta n}$	100% $I_{\Delta n}$ +0%-20%
Relay output residual non-operating current at 50/60 Hz	$I_{\Delta no}$	50% $I_{\Delta n}$ +20%-0%
Frequency dependence of residual operating current	$I_{\Delta n, freq}$	150 Hz: 2.4 · $I_{\Delta n}$ 400 Hz: 6 · $I_{\Delta n}$ 1000 Hz: 14 · $I_{\Delta n}$ (or 2 Arms max)
Frequency dependence of residual non-operating current	$I_{\Delta n, freq}$	150 Hz: 0.5 · $I_{\Delta n}$ 400 Hz: 0.5 · $I_{\Delta n}$ 1000 Hz: 1 · $I_{\Delta n}$
Rated analog output residual current (20 mA)	$I_{an}$	0.4 Arms $\pm 6\%$ ( $I_{\Delta n}=30-300$ mA) 2 Arms $\pm 6\%$ ( $I_{\Delta n}=0.5-1$ A)
Hysteresis on relay output (for non-latched operation)	$I_{\Delta n, hyst}$	$< 30\%$ $I_{\Delta n}$
Integration time	$T_i$	Short (100 ms), Medium (400 ms), Long (1000 ms)

## Supply voltage

Parameter	Symbol	Value
Rated supply voltage	$U_e$	24 Vdc +10%/-15%
Oversvoltage category	OVC <sub>e</sub>	III
Rated impulse withstand voltage	$U_{impe}$	1.5 kV
Rated insulation voltage	$U_{ie}$	30 V
Internal consumption	$P_e$	$< 4$ W

## Relay output

Parameter	Symbol	Value
Contact output		NO+NC
Rated voltage	$U_r$	30 Vac/dc
Rated current	$I_r$	1 Aac/dc
Maximum Actuating time 1x $I_{\Delta n}$	$t_r, 1x I_{\Delta n}$	$\leq T_i + 1 / (2 f_{rc})^{**}$
Maximum Actuating time 5x $I_{\Delta n}$	$t_r, 5x I_{\Delta n}$	$\leq T_i/16 + 1 / (2 f_{rc})^{**}$
Response threshold $I_{\Delta n}$		100% +0-20%
Latching function with Reset (int/ext)		Yes
Minimum non-actuating time	$t_{nr}, 1x I_{\Delta n}$	$\leq T_i/2$
Switching operations		$> 20,000$

## Environmental and mechanical characteristics

Parameter	Unit	Min	Typ	Max	Comment
Operating temperature range	°C	-20		55	
Storage temperature range	°C	-40		85	
Relative humidity	%	20		80	Non-condensing
Mass	kg		0.900		
Connector	Phoenix Contact DFMC 1,5/ 5-ST-3,5-LR — PN: 1790519 or compatible				
Standards	EN / IEC 62020-1:2020				



## Dimensions

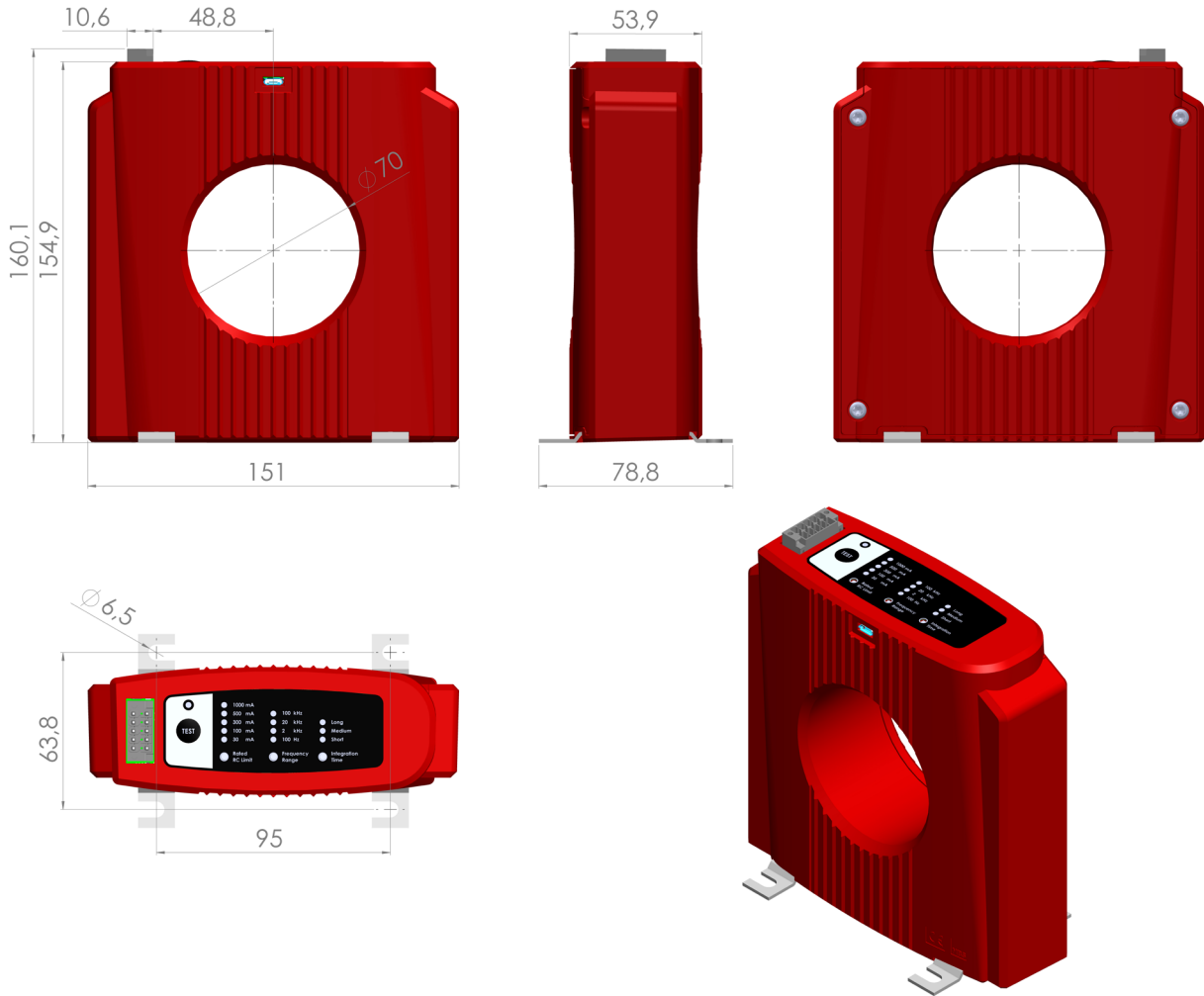

(general tolerance 0.3mm unless otherwise stated)

Base plate mounting with screws in the four holes of the foot angles.

### Optional accessories

Power supply for DIN-rail mounting



Input:

85-264V AC  
120-370V DC

Output:

20W  
24V DC ( $\pm 2\%$ )

Item No.:

120-00003

## Compatible accessory

### Accessory: centring aid

- Accurate measurements even with supply cables with smaller diameters -

The RCMB 70 residual current monitor must be crossed by all active conductors. The protective conductor must be led outside the device or once in each direction. When switching high loads, high currents and their magnetic fields can lead to unwanted interference or influence on the measurement results. The arrangement of the conductors must therefore be optimized as shown in the following illustrations.

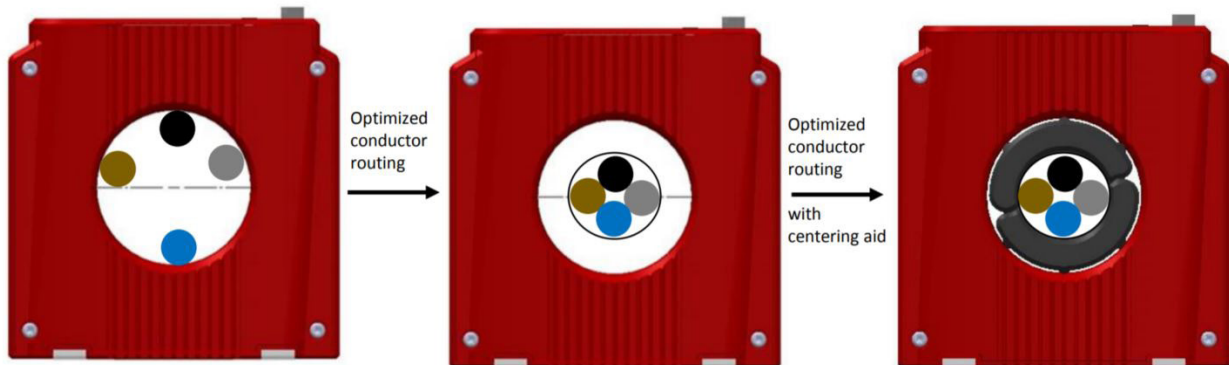

When the conductors are brought together with subsequent centering in the inner diameter, disturbances and inaccuracies can be significantly reduced. A centering aid can be ordered as an accessory in order to implement this optimized conductor routing in practice. This consists of EPP foam (expanded polypropylene) and is cut to the appropriate diameter with a sharp knife. If necessary, the individual conductors can also be brought together with cable ties before and after the passage.

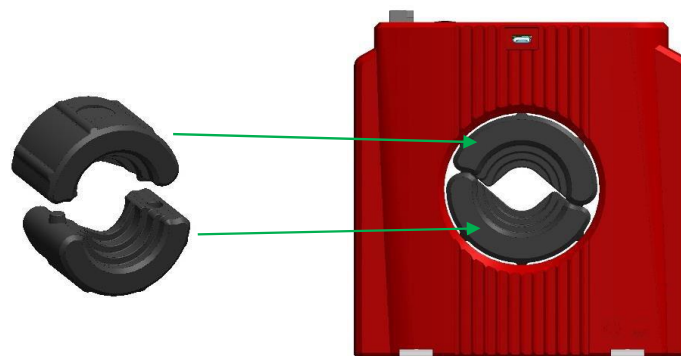

Product	Item number
Residual Current Monitor RCMB 70 (70 mm inner diameter)	DA07002B
Centring aid Compatible for the RCMB 70	55029



- Current transformers for industry
- Current transformers for tariffs
- Accessories for current transformers
- Medium-voltage transformers
- Bus bar insulators / -supports
- Shunts

- Voltage transformers
- All current sensors
- Measuring transducers
- Energy meters with or without MID approval
- Accessories for energy meters
- Panel board heaters, filter fans, roof fans and control units



[www.mbs-ag.com](http://www.mbs-ag.com)

**MBS AG**  
Eisbachstraße 51 74429 Sulzbach-Laufen Germany  
Phone: +49 7976 9851-0 Telefax: +49 7976 9851-90  
[info@mbs-ag.com](mailto:info@mbs-ag.com) [www.mbs-ag.com](http://www.mbs-ag.com)

