

Instruction manual / Assembly instructions

Please keep!

**Low voltage current transformer
- Window type ct -**

Series XCTB



MBS AG

Eisbachstraße 51

74429 Sulzbach-Laufen

Tel. +49 7976 9851-0

Fax. +49 7976 9851-90

info@mbs-ag.com • www.mbs-ag.com

Before installing, commissioning or operating the device, please read this manual completely and carefully.

1. Safety instructions



Attention

The following points should be noted:

- The applicable laws, standards and regulations.
- The state of the art at the time of installation.
- The rules of technology.
- The user manual.
- The fact that a manual can only be general and that these instructions must be followed.
- Before commissioning, carefully inspect the device for possible transport damage. In the event of mechanical damage, the device must not be put into operation.
- The devices described are intended for installation by qualified electricians and may only be installed in electrical service rooms or in enclosed enclosures. Any other use or failure to comply with this application notice will void the warranty.
- The devices may only be installed in dry indoor areas.
- Do not install on or on highly flammable materials.
- Operation with a rated current higher than that specified on the rating plate can overheat the current transformer

2. Function Description

Current transformers of the XCTB series are inductive current transformers. They are used in order to transform the primary measured value into a smaller current which fits with the connected measuring instruments.

Due to the applied measuring principle, these current transformers are suitable for use in AC networks only.

Current transformers of the XCTB series are maintenance-free.

3. Warning notes



Attention

Dangerous electrical voltage can cause electric shock and burns.

Make sure that the data on the type plate and in the "Technical Data" under point 5 correspond to the operating parameters of the system.

Switch off the system before starting installation work!



Attention

In a non-loaded (open) secondary circuit of the current transformer high voltages are induced at the secondary terminals. The occurring voltage values represent a danger to persons as well as the reliability of the current transformer.

An "open operation", i.e. operation of the current transformer without secondary wiring, is absolutely to be avoided.

4. Installation

- Ensure a safe working environment during installation, maintenance and installation work. Disconnect the power supply of the primary conductor and secure it against unintentional restart.
- Install the current transformer on the primary conductor.
- To do this, put the primary conductor (copper rail or round conductor) through the window opening of the current transformer housing. The window of the ct is marked with "K-P1" or "L-P2".
- The device can be mounted either directly on the primary conductor or on a mounting plate. Use the fasteners included in the delivery. The direct attachment to the primary conductor is carried out by screwing the fastening screws contained in the accessories pack into the screw domes on the converter housing or with the optionally available Quick-Fix (Order No. 55021). The mounting on mounting plate is done by means of the foot angle also included in the accessories.
- Current transformers of the types XCTB 31.35 and XCTB 41.35 can also be attached to a 35 mm DIN rail by means of a snap-on attachment (Order No. 55015) available as an accessory.
- Make the secondary connections. Note the marking "k-S1" and "l-S2" of the secondary terminals

4.1. Measuring circuit

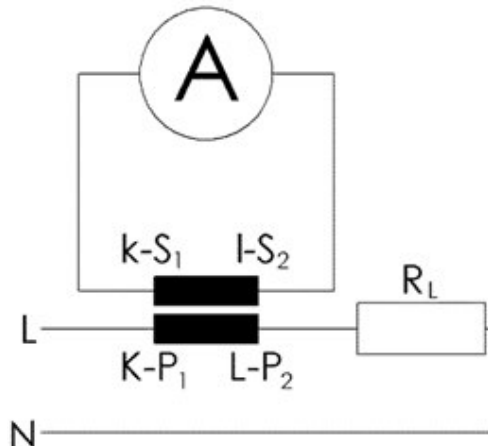

4.2. Installation instructions

Actuation of secondary terminal clamps (CAGE CLAMP®)

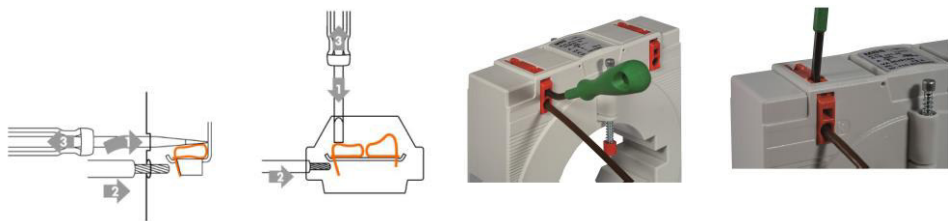

Assembly of the fixing screws



Mounting on copper rail or round conductor

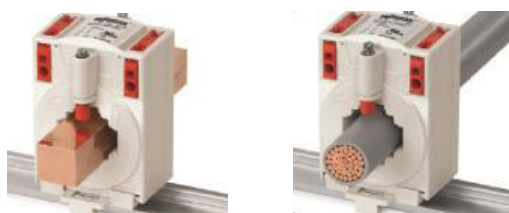

Assembly with Quick-Fix



Mounting on 35 mm DIN rail with snap-on mounting (only XCTB 31.35 and XCTB 41.35)



Mounting on mounting plate

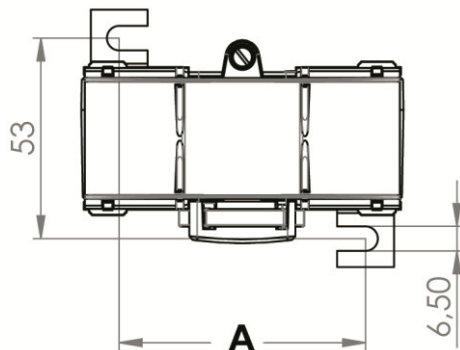

	XCTB 31.35	XCTB 41.35	XCTB 51.35	XCTB 61.35	XCTB 81.35	XCTB 101.35
Measure „A“ [mm]	40	40	65	65	95	95

Mounted cover seal



4.3 Notes on measuring the current harmonics

4.3.1 Connection cable for current transformer - measuring device

For measurements up to 20 kHz, please note that the connection cable can influence the measurement accuracy. Class accuracy according to the applied second rating plate on the converter can only be guaranteed by MBS AG with the following cable type.

Manufacturer: Helukabel (<http://www.helukabel.com>)

Cable type (As of 5th of March in.2018):

OZ-500 HMH-C mit 2 x **2,5 mm²** (item number 11744)

OZ-500 HMH-C mit 2 x **4 mm²** (item number 11766)

datasheet: https://www.helukabel.de/de/produkte/jz-500-hmh-c-oz-500-hmh-c-opc-STD_11656.html

Connection length: 0-10 m

It is a twisted, shielded and halogen-free cable.

When laying the cable, make sure that no closed loop is laid. The shielding is grounded at both ends.

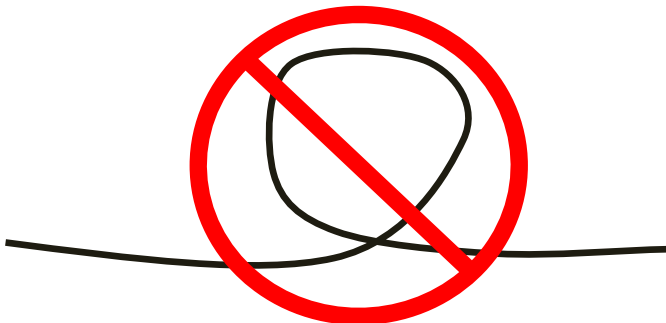

5. Technical data (for details see rating plate)

5.1. General technical data

Input sizes

Rated primary current I_{pr} :	see below 5.2.
Rated continuous thermal current I_{cth} :	$1,2 \times I_{pr}$
Rated short-time thermal current I_{th} :	$60 \times I_{pr} / 1s$ (max. 100kA)
Rated dynamic current I_{dyn} :	$2,5 \times I_{th}$
Rated frequency f_R :	50 ... 60 Hz

Output sizes

Rated secondary current I_{sr} :	5A oder 1A
Accuracy class (depending on type):	0,2s ... 1
Rated output S_r (depending on type):	0,5 ... 5 VA
Instrument security factor FS:	FS5 bzw.FS10

Operating conditions

Ambient temperature:	-5...+50 °C
Storage temperature:	-25 ... +70 °C
Relative humidity (no condensation):	5 ... 85 %
Altitude:	up to 1000 m

Insulation properties

Highest voltage for equipment U_m (in accordance with IEC 61010-1 under the following conditions: - overvoltage category III - pollution degree 2 - heterogeneous electric field):	1,2/6/- kV
Surge resistance in accordance with DIN EN 61439-1: 2012-06:	12 kV (1,2/50 μ s)
Insulation class:	E

Security

Degree of protection:

IP20

Body material :

PC

Connection

Conductor feedthrough primary:

see below 5.2.

Secondary connection technology:

CAGE CLAMP®

Connection cross-section secondary:

2.5 – 4 mm² /

AWG 14-12

Stripping length:

9 – 10 mm / 0.37 in

In compliance with:

IEC 61869-1

IEC 61869-2

IEC 61010-1

The latest edition of the mentioned documents applies, including all changes.

5.2. Technical data type-related

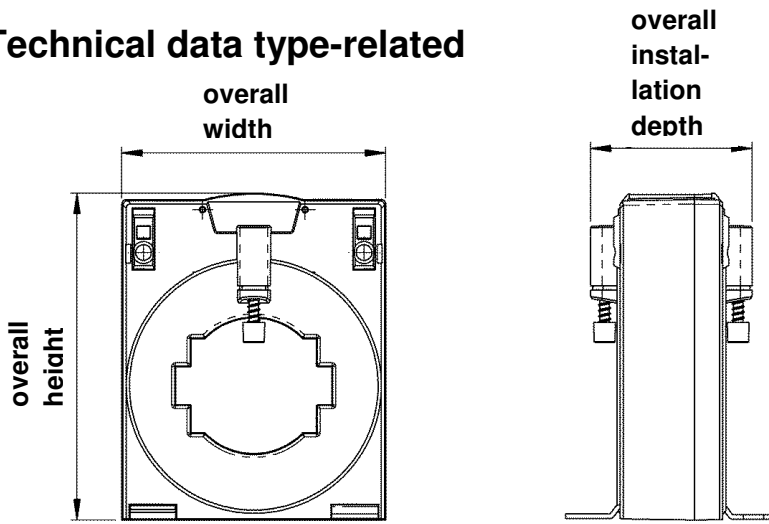

	XCTB 31.35	XCTB 41.35	XCTB 51.35	XCTB 61.35	XCTB 81.35	XCTB 101.35
Rated primary current [A]	50...750	75...1000	100...1250	200...1600	400...2000	400...2000
Conductor feedthrough primary						
busbar 1 [mm]	30 x 10	40 x 10	50 x 12	63 x 10	80 x 10	100 x 10
busbar 2 [mm]	25 x 12	30 x 15	40 x 30	50 x 30	60 x 30	80 x 30
busbar 3 [mm]	20 x 20	---	---	---	---	---
Round conductor [mm]	25.7	31.8	43.7	43.7	54.7	70
Dimensions						
width [mm]	60	70	85	95	120	130
height [mm]	80,5	91,15	105,25	114,86	134,66	147,49
overall depth [mm]	52	52	52	52	52	52

5.3. Identification of the rating plate

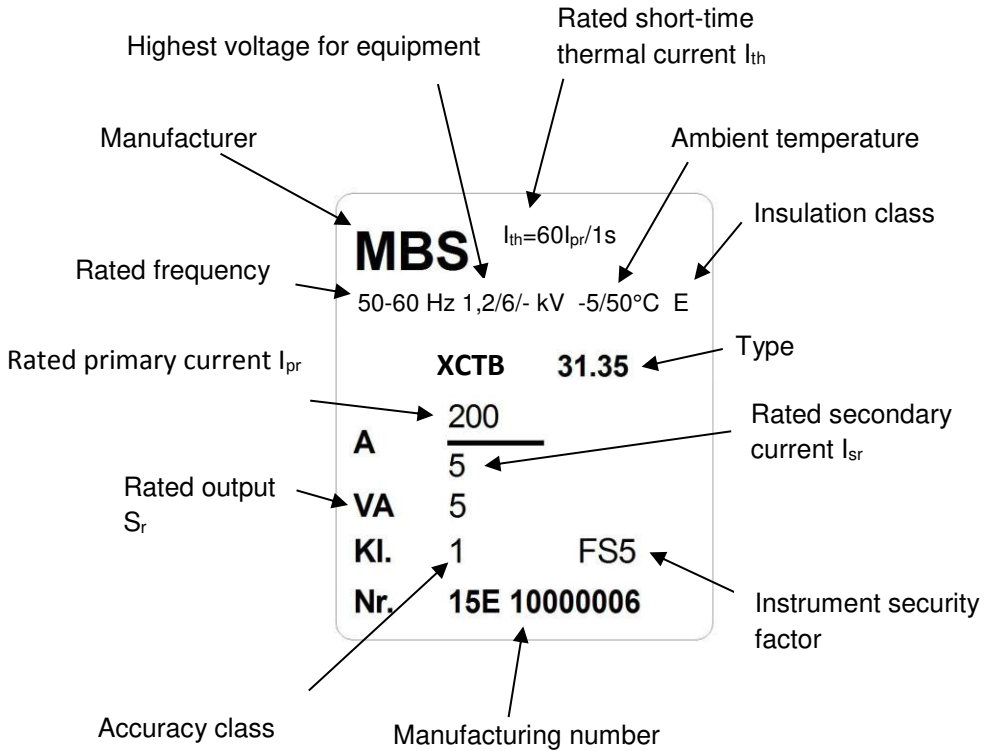

5.4. Second rating plate regarding frequency

permissible load for the guaranteed accuracy class - the rated power S_r can be found on the rating plate

Attention: The measuring instruments must represent a purely resistive load.

Amplitude error

first
frequency section

second
frequency section

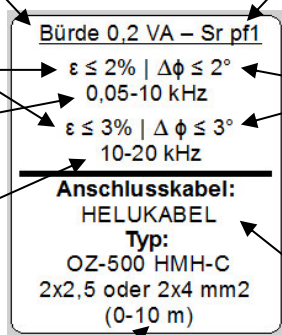

Phase displacement

Required EMC connection cable

Maximum cable length: 10 m

Attention: The instrument security factor FS only applies to the nominal load S_r on the main rating plate under 5.3.

6. Additional equipment

Snap-on mounting for
top hat rail 35 mm
(Type XCTB 31.35 and XCTB 41.35)

Order no. 55021



Quick-Fix

Order no. 55021

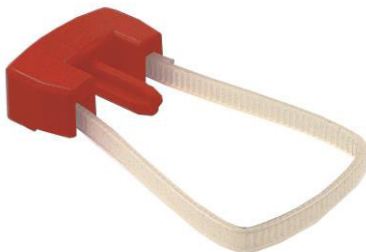

Cover seal

Order no.:

59057 XCTB 31.35
XCTB 41.35

59058 XCTB 51.35

59059 XCTB 61.35
XCTB 81.35
XCTB 101.35



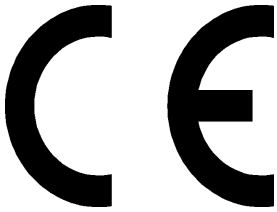

This product was made in compliance with the applicable standards (IEC 61010, IEC 61869) and meets the requirements of the

Low Voltage Directive 2014/35 / EU.



MBS AG hereby declares that its products use only components from qualified manufacturers whose specifications meet or exceed the requirements of the EU directive on the restriction of the use of certain hazardous substances.

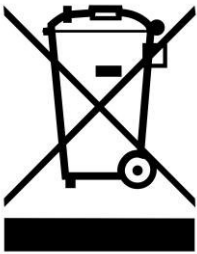

When the product reaches the end of its life, it must be recycled. Do not discard with household waste!

If necessary, ask a waste consultant!



MBS AG

Eisbachstrasse 51 • 74429 Sulzbach-Laufen • Germany

Telefon: +49 7976 9851-0 • Telefax: +49 7976 9851-90

info@mbs-ag.com • www.mbs-ag.com